

ELECTRICAL SPECIFICATION

Parameter	Symbol	Value	Units
Input Voltage	V_{in}	90 – 265	VAC
Output Voltage	V_{out}	20	V
LED Current	I_{LED}	350	mA
Output Power	P_{out}	7	W
Efficiency (full load)	η	84–87	%
PF		>0.9	

DESCRIPTION

The MP4026 is a primary-side-control, offline LED controller that achieves high-power factor and accurate LED current for isolated, single-power-stage lighting applications in an FCTSOT package. The proprietary real-current-control method accurately controls LED current from primary-side information with good line and load regulation. The primary-side-control eliminates the secondary-side feedback components and the opto-coupler to significantly simplify LED-lighting-system design.

The MP4026 integrates power-factor correction and works in boundary-conduction mode to reduce MOSFET switching losses.

The MP4026's multiple protection features greatly enhance system reliability and safety. These features include over-voltage protection, short-circuit protection, primary-side over-current protection, brown out protection, cycle-by-cycle current limiting, V_{CC} under-voltage lockout, and auto-restart over-temperature protection.

FEATURES

- Real-Current Control without Secondary-Feedback Circuit
- Good Line/Load Regulation
- High Power Factor (≥ 0.9) over Universal Input Voltage
- Boundary Conduction Mode for Improved Efficiency
- Brown-Out Protection
- Over-Voltage Protection
- Short-Circuit Protection
- Over-Temperature Protection
- Primary-Side Over-Current Protection
- Cycle-by-Cycle Current Limit
- Input UVLO
- Available in FCTSOT-6

APPLICATIONS

- Industrial and Commercial Lighting
- Residential Lighting

All MPS parts are lead-free and adhere to the RoHS directive. For MPS green status, please visit MPS website under Products, Quality Assurance page.

"MPS" and "The Future of Analog IC Technology" are registered trademarks of Monolithic Power Systems, Inc.

TYPICAL APPLICATION CIRCUIT

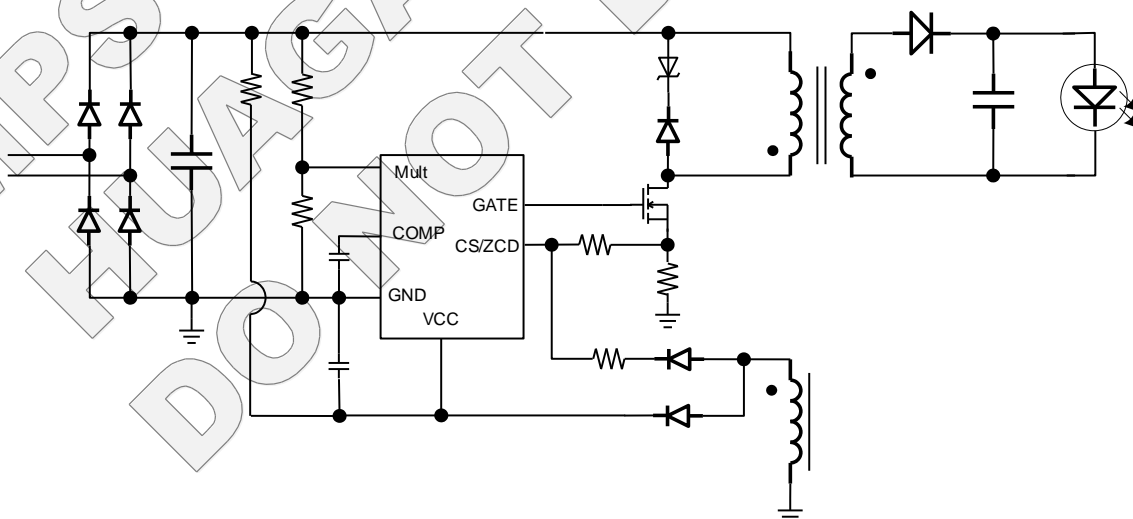

ORDERING INFORMATION

Part Number	Package	Top Marking
MP4026GJ*	FCTSOT-6	AFS

* For Tape & Reel, add suffix -Z (e.g. MP4026GJ-Z);

PACKAGE REFERENCE

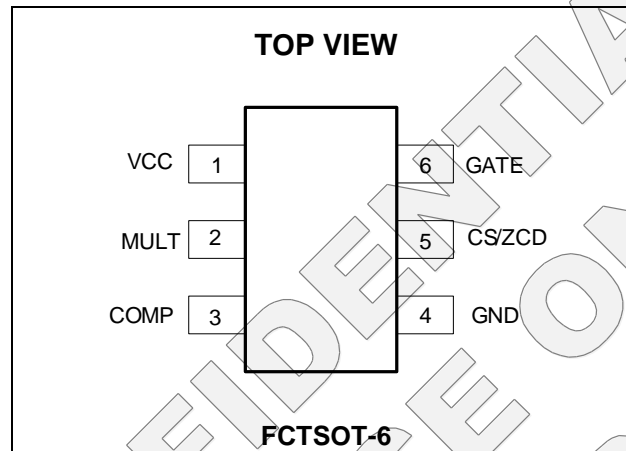

ABSOLUTE MAXIMUM RATINGS ⁽¹⁾

Input Voltage V_{CC}	-0.3V to +30V
Gate Drive Voltage	-0.3V to +15V
ZCD Pin.....	-0.3V to 6.5V
Other Analog Inputs and Outputs..	-0.3V to 6.5V
Max. Gate Current	±0.6A
Continuous Power Dissipation ($T_A =$ +25°C) ⁽²⁾	
FCTSOT-6.....	1.25W
Junction Temperature	150°C
Lead Temperature	260°C
Storage Temperature.....	-65°C to +150°C

Recommended Operating Conditions ⁽³⁾

Supply Voltage V_{CC}	9.5V to 27V
Maximum Junction Temp. (T_J)	+125°C

Thermal Resistance ⁽⁴⁾

	θ_{JA}	θ_{JC}
FCTSOT-6.....	100....	55.. °C/W

Notes:

- 1) Exceeding these ratings may damage the device.
- 2) The maximum allowable power dissipation is a function of the maximum junction temperature T_J (MAX), the junction-to-ambient thermal resistance θ_{JA} , and the ambient temperature T_A . The maximum allowable continuous power dissipation at any ambient temperature is calculated by P_D (MAX) = $(T_J$ (MAX)- T_A)/ θ_{JA} . Exceeding the maximum allowable power dissipation will cause excessive die temperature, and the regulator will go into thermal shutdown. Internal thermal shutdown circuitry protects the device from permanent damage.
- 3) The device is not guaranteed to function outside of its operating conditions.
- 4) Measured on JESD51-7, 4-layer PCB.

ELECTRICAL CHARACTERISTICS

$T_A = +25^\circ\text{C}$, unless otherwise noted.

Parameter	Symbol	Condition	Min	Typ	Max	Units
Supply Voltage						
Operating Range	V_{CC}	After turn on	9.5		27	V
Turn-On Threshold	V_{CC_ON}	V_{CC} rising edge	23	24	25	V
Turn-Off Threshold	V_{CC_OFF}	V_{CC} falling edge	8.55	9.0	9.45	V
Hysteretic Voltage	V_{CC_HYS}		14	15	16	V
Supply Current						
Start-up Current	$I_{STARTUP}$	$V_{CC} = V_{CC_ON} - 1V$		20	30	μA
Quiescent Current	I_Q	No switching		0.5	0.6	mA
Operating Current Under Fault Condition		No switching		2.3		mA
Operating Current	I_{CC}	$f_s = 70\text{kHz}$, $C_{GATE} = 1\text{Nf}$		2	3	mA
Multiplier						
Linear Operation Range	V_{MULT}		0		3	V
Gain	$K^{(5)}$			1.2		1/V
Brown-Out Protection Threshold			285	300	315	mV
Brown-Out Detection Time			25	36	47	ms
Brown-Out-Protection-Hysteretic Voltage			90	100	110	mV
Error Amplifier						
Feedback Voltage	V_{FB}		0.403	0.414	0.425	V
Transconductance ⁽⁶⁾	G_{EA}			125		$\mu\text{A/V}$
Upper Clamp Voltage	V_{COMP_H}		5	5.25	5.5	V
Lower Clamp Voltage	V_{COMP_L}		1.42	1.5	1.58	V
Max. Source Current ⁽⁶⁾	I_{COMP}			50		μA
Max. Sink Current ⁽⁶⁾	I_{COMP}			-400		μA
Current Sense Comparator and Zero Current Detector						
CS/ZCD Bias Current	$I_{BIAS_CS/ZCD}$				100	nA
Leading-Edge-Blanking Time	t_{LEB_CS}			400		ns
Current-Sense-Clamp Voltage	V_{CS_CLAMP}		1.9	2.0	2.1	V
Over-Current-Protection, Leading-Edge-Blanking Time	t_{LEB_CSOCP}			280		ns
Over-Current-Protection Threshold	V_{CS_OCP}		2.4	2.5	2.6	V
Zero-Current-Detection Threshold	V_{ZCD_T}	V_{ZCD} falling edge	0.285	0.3	0.315	V
Zero-Current-Detect Hysteresis	V_{ZCD_HYS}		617	650	683	mV

ELECTRICAL CHARACTERISTICS (continued)
 $V_{CC} = 20V$, $T_A = +25^\circ C$, unless otherwise noted.

Parameter	Symbol	Condition	Min	Typ	Max	Units
ZCD Blanking Time	t_{LEB_ZCD}	After turn-off, $V_{MULT_O} > 0.3V$		1.5		μs
	t_{LEB_ZCD}	After turn-off, $V_{MULT_O} \leq 0.3V$		0.75		μs
Over-Voltage Blanking Time	t_{LEB_OVP}	After turn-off, $V_{MULT_O} > 0.3V$		1.5		μs
	t_{LEB_OVP}	After turn-off, $V_{MULT_O} \leq 0.3V$		0.75		μs
Over-Voltage Threshold	V_{ZCD_OVP}	1.5 μs delay after turn-off	4.95	5.1	5.25	V
Minimum Off Time	t_{OFF_MIN}		4	5	6	μs
Starter						
Start-Timer Period	t_{START}			190		μs
Gate Driver						
Output-Clamp Voltage	V_{GATE_CLAMP}	$V_{CC} = 27V$	12.5	13.5	14.5	V
Minimum-Output Voltage	V_{GATE_MIN}	$V_{CC} = V_{CC_OFF} + 50mV$	6			V
Max. Source Current ⁽⁶⁾	I_{GATE_SOURCE}			0.8		A
Max. Sink Current ⁽⁶⁾	I_{GATE_SINK}			-1		A

Notes:

 5) The multiplier output is given by: $V_{CS} = k * V_{MULT} * (V_{COMP} - 1.5)$

6). Guaranteed by design.

TYPICAL PERFORMANCE CHARACTERISTICS

$V_{IN} = 90V-265V$, $V_{OUT} = 10-20V$, $I_{LED}=350mA$, $T_A = 25^\circ C$, unless otherwise noted.

Line/Load Regulation

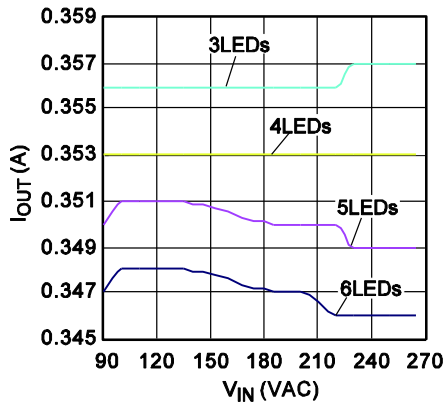

Efficiency

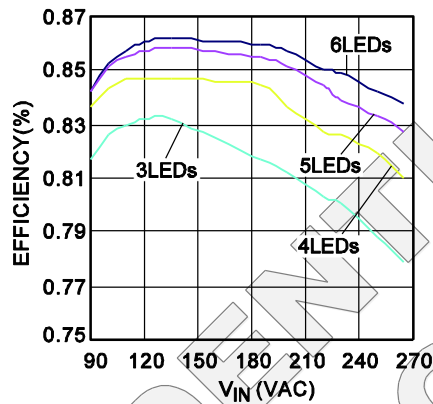

PF @Full Load

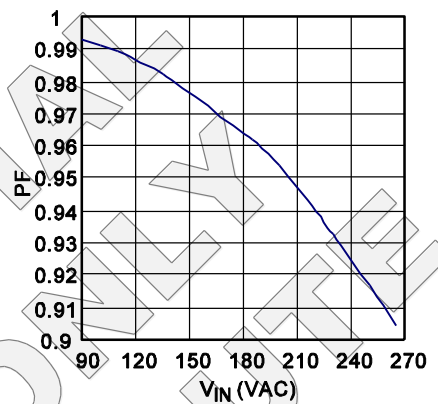

Steady State $V_{IN} = 110V$

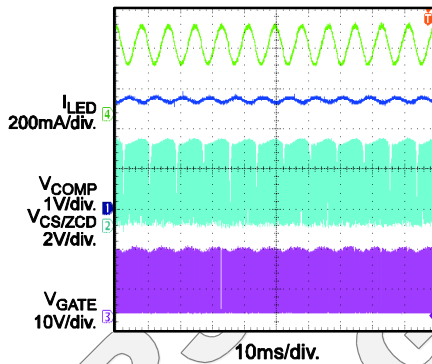

Steady State $V_{IN} = 110V$

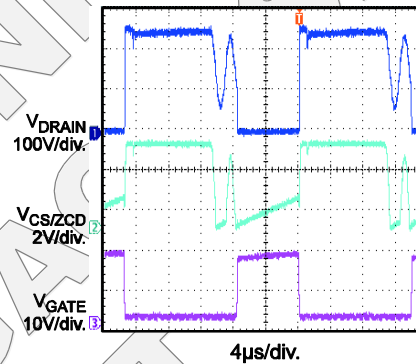

Steady State $V_{IN} = 110V$

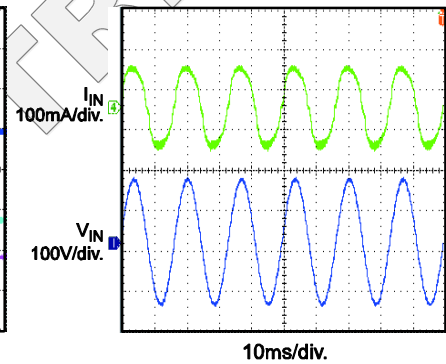

Steady State $V_{IN} = 230V$

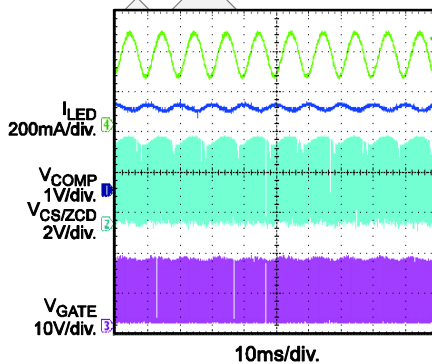

Steady State $V_{IN} = 230V$

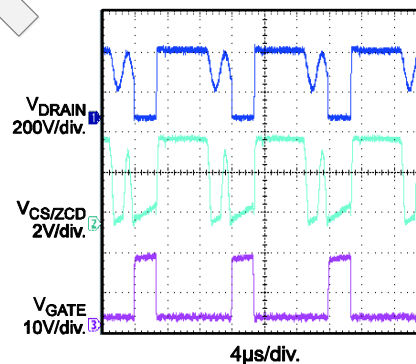

Steady State $V_{IN} = 230V$

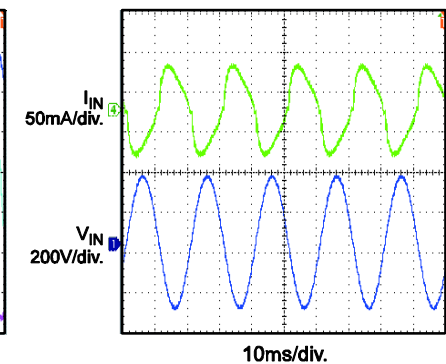

TYPICAL PERFORMANCE CHARACTERISTICS (continued)

$V_{IN} = 90V-265V$, $V_{OUT} = 10-20V$, $I_{LED}=350mA$, $T_A = 25^\circ C$, unless otherwise noted.

VIN Start up
 $V_{IN} = 110V$

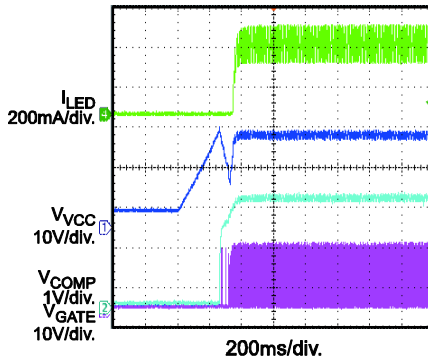

VIN Start up
 $V_{IN} = 230V$

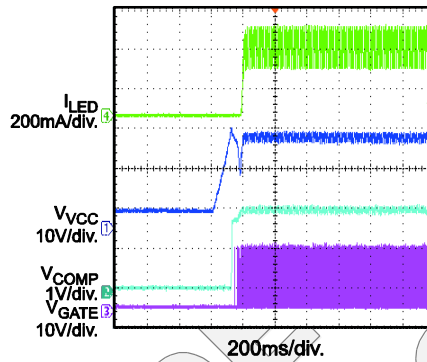

Open LED Protection
 $V_{IN} = 110V$, Open LED @ Working

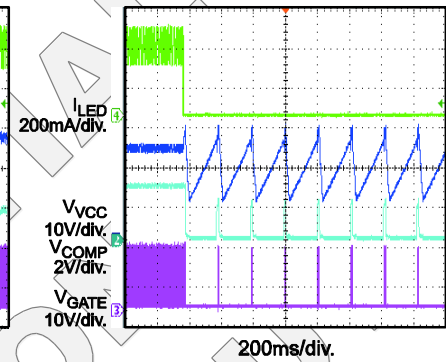

Open LED Protection
 $V_{IN} = 230V$, Open LED @ Working

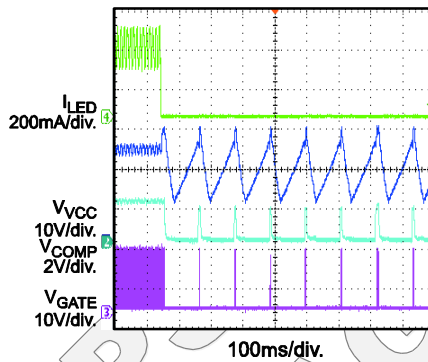

Short Circuit Protection
 $V_{IN} = 110V$
Short LED+ to LED- @ Working

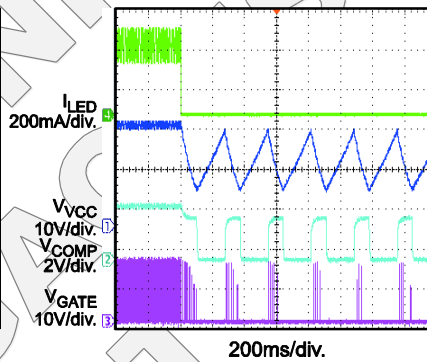

Short Circuit Protection
 $V_{IN} = 230V$
Short LED+ to LED- @ Working

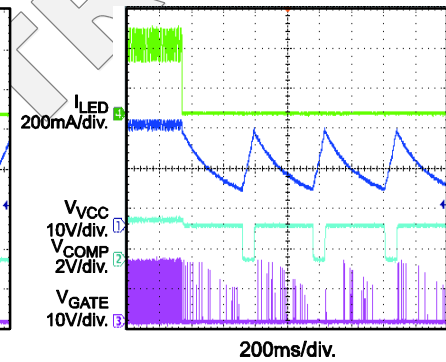

Primary-Side OCP Protection
 $V_{IN} = 110V$
Short primary winding @ Working

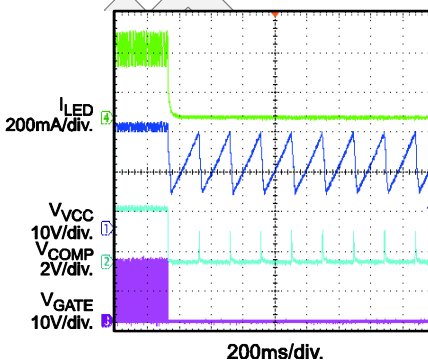

Primary-Side OCP Protection
 $V_{IN} = 230V$
Short primary winding @ Working

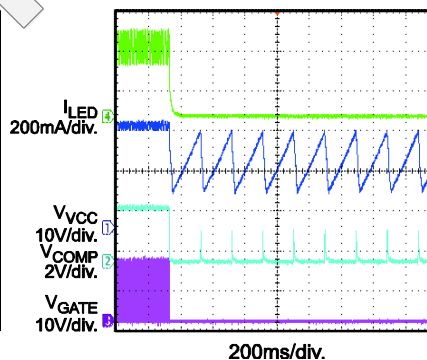

PIN FUNCTIONS

Pin	Name	Description
1	VCC	Power Supply. Supplies power for the control signals and the high-current MOSFET. Bypass to ground with an external bulk capacitor (typically 4.7 μ F).
2	MULT	Input Voltage Sense. Connect to the tap of resistor divider between the rectified AC line and GND. The half-wave sinusoid provides a reference signal for the internal-current-control loop. The MULT pin is also used for brown-out protection detection.
3	COMP	Loop Compensation. Connect a compensation network to stabilize the LED driver and maintain an accurate LED current.
4	GND	Ground. Current return for the control signal and the gate-drive signal.
5	CS/ZCD	Current Sense or Zero-Current Detection. When the gate driver turns on, a sensing resistor senses the MOSFET current. The comparison between the sensed voltage and the internal sinusoidal-current reference determines when the MOSFET turns off. If the pin voltage exceeds the current limit (2.0V, after turn-on blanking) the gate drive turns off. When the gate driver turns off, the negative falling-edge (after the blanking time) triggers the external MOSFET's turn-on signal. Connect this pin to a resistor divider through a diode between the auxiliary winding and GND. Over-voltage condition is detected through ZCD. For every turn-off interval, if the ZCD voltage exceeds the over-voltage-protection threshold after the 1.5 μ s ($V_{mult_o} > 0.3V$) or 0.75 μ s ($V_{mult_o} \leq 0.3V$) blanking time, over-voltage protection triggers and the system stops switching until auto-restart. CS/ZCD is also used for primary-side over-current-protection, if the sensing voltage reaches to 2.5V after a blanking time at gate turn-on interval, the primary-side over-current-protection triggers and the system stops switching until auto-restart. A 10pF ceramic cap is recommended to connect from CS/ZCD to GND to bypass the high frequency noise. In order to reduce the RC delay influence to the sample accuracy of the current sensing signal, the CS/ZCD down side resistance (R_{ZCD2} in figure 7) should be smaller than 3k Ω .
6	GATE	Gate Drive Output. This totem-pole output stage can drive a high-power MOSFET with a peak current of 0.8A source and 1A sink. The high-voltage limit is clamped to 13.5V to avoid excessive gate-drive voltage. The low-voltage is higher than 6V to guarantee a sufficient drive capacity.

FUNCTION DIAGRAM

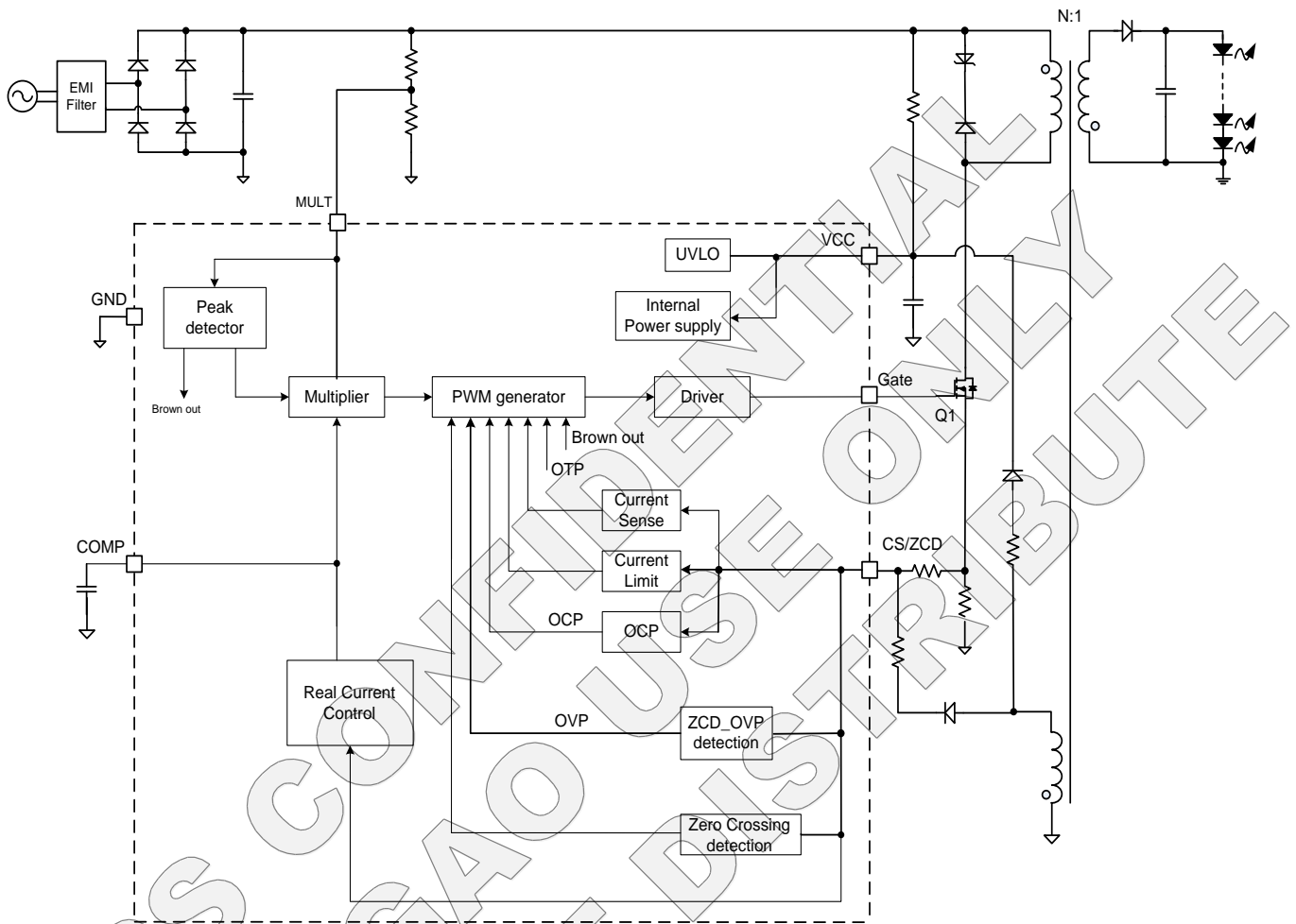

Figure 1—MP4026 Function Block Diagram

OPERATION

The MP4026 is a primary-side-controlled, offline LED controller for high-performance LED lighting. It has primary-side real-current control for accurate LED current regulation. It also has active power factor correction (PFC) to eliminate harmonic noise on the AC line. The rich protections can achieve a high safety and reliability in real application.

Start Up

Initially, AC line charges up V_{CC} through the start-up resistor. When V_{CC} reaches 24V, the control logic starts. Then the power supply is taken over by the auxiliary winding when the voltage of auxiliary winding builds up.

The MP4026 will shut down when V_{CC} drops below 9V.

The high hysteretic voltage allows for a small VCC capacitor (typically 4.7 μ F) to shorten the start-up time.

Boundary-Conduction Mode

During the external MOSFET ON-time (t_{ON}), the rectified-input voltage (V_{BUS}) charges the primary-side inductor (L_m), and the primary-side current (I_p) increases linearly from zero to the peak value (I_{PK}). When the external MOSFET turns OFF, the energy stored in the inductor transfers to the secondary-side and turns on the secondary-side diode to power the load. The secondary current (I_s) then decreases linearly from its peak value to zero. When the secondary current decreases to zero, the primary-side-leakage inductance, magnetizing inductance, and the parasitic capacitances decrease the MOSFET drain-source voltage—this decrease is also reflected on the auxiliary winding (see Figure 2). The zero-current detector in the CS/ZCD pin generates the external MOSFET's turn-on signal when the ZCD voltage falls below 0.3V (see Figure 3).

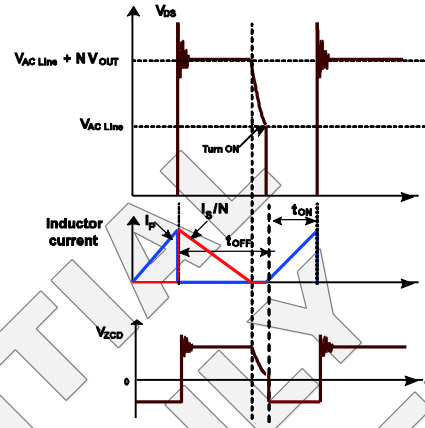

Figure 2: Boundary-Conduction Mode

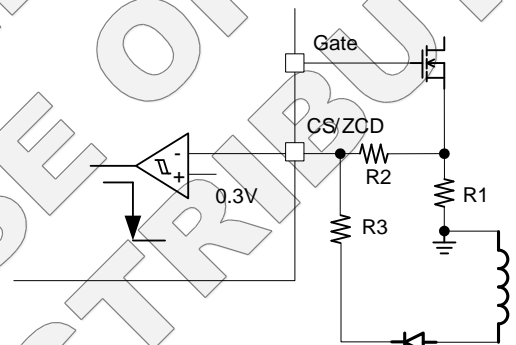

Figure 3: Zero-Current Detector

As a result, there are virtually no primary-switch turn-on losses and no secondary-diode reverse-recovery losses, ensuring high efficiency and low EMI noise.

Real-Current Control

The proprietary real-current-control method allows the MP4026 to control the secondary-side LED current using primary-side information. The mean output LED current is approximately:

$$I_o \approx \frac{N \cdot V_{FB}}{2 \cdot R_s}$$

Where:

- N is the primary-side-to-secondary-side turn ratio,
- V_{FB} is the feedback reference voltage (typically 0.414V), and
- R_s is the sensing resistor connected between the MOSFET source and GND.

Power-Factor Correction

The MULT pin is connected to a pull up resistor from the rectified-instantaneous-line voltage and fed as one input of the Multiplier. The multiplier output is sinusoidal. This signal provides the reference for the current comparator and comparing with the primary-side-inductor current, which sets the sinusoidal primary-peak current. This helps to achieve a high-power factor.

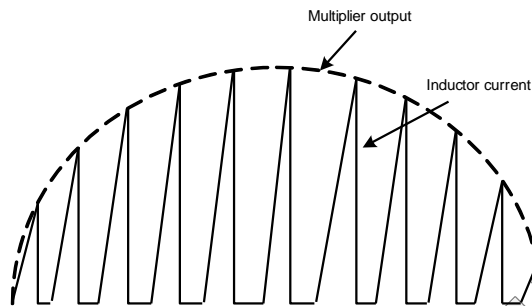

Figure 4: Power-Factor Correction

The maximum voltage of the multiplier output to the current comparator is clamped at 2V for a cycle-by-cycle current limit.

VCC Under-Voltage Lockout

When V_{CC} drops below the UVLO threshold (9V), the MP4026 stops switching and shuts down. The operating current is very low under this condition, the V_{CC} will be charged up again by the external start up resistor from AC line. Figure 5 shows the typical V_{CC} under-voltage lockout waveform.

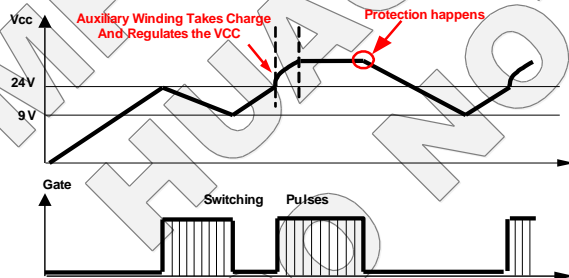

Figure 5: VCC Start-Up Waveform

Auto Starter

The MP4026 has an integrated auto starter. The starter times when the MOSFET is OFF: If ZCD fails to send out another turn-on signal after 190 μ s, the starter will automatically send out the turn-on signal to avoid unnecessary shutdowns

due to missing ZCD detections.

Minimum Off Time

The MP4026 operates with a variable switching frequency; the frequency changes with the instantaneous-input-line voltage. To limit the maximum frequency and get a good EMI performance, the MP4026 employs an internal, minimum-off-time limiter—5 μ s.

Leading-Edge Blanking

To avoid premature switching-pulse termination due to the parasitic capacitances discharging when the MOSFET turns on at normal operation, the MP4026 uses an internal-leading edge blanking (LEB) unit between the CS/ZCD pin and the current-comparator input. During the blanking time, the path from the CS/ZCD pin to the current comparator input is blocked. Figure 6 shows the leading-edge blanking. The LEB time of primary-side OCP detection is relatively short, 280ns.

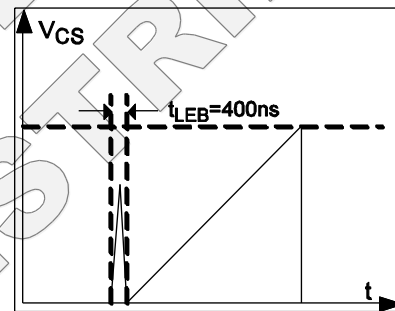

Figure 6: Leading-Edge Blanking

Output Over-Voltage Protection

Output over-voltage protection prevents component damage during an over-voltage condition. The auxiliary-winding voltage's positive plateau is proportional to the output voltage: the OVP uses the auxiliary winding voltage instead of directly monitoring the output voltage. Figure 7 shows the OVP sampling unit. Once the ZCD voltage exceeds 5.1V at gate turn off interval, the OVP signal will be triggered and latched, the gate driver will be turned off and the IC works at quiescent mode, the V_{CC} voltage dropped below the UVLO which will make the IC shut down, and the system restarts again.

The output-OVP-set point is then:

$$V_{OUT_OVP} \cdot \frac{N_{AUX}}{N_{SEC}} \cdot \frac{R_{ZCD2}}{R_{ZCD1} + R_{ZCD2}} = 5.1V$$

Where:

- V_{OUT_OVP} is the output-over-voltage-protection point,
- N_{AUX} is the number of auxiliary-winding turns, and
- N_{SEC} is the number of secondary-winding turns.

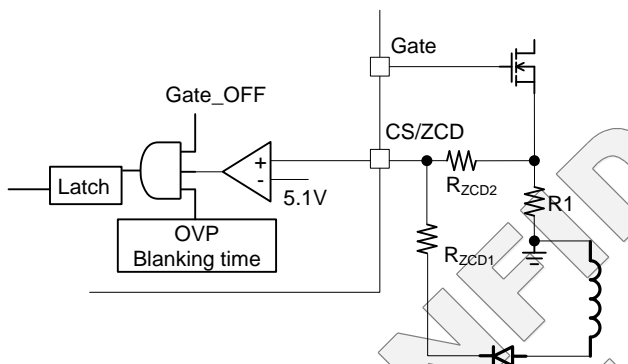

Figure 7: OVP Sampling Unit

To prevent a voltage spike from mis-triggering OVP after the switch turns off, OVP sampling has a t_{LEB_OVP} blanking period (typically $1.5\mu s$ when $V_{MULT_O} > 0.3V$ and $0.75\mu s$ when $V_{MULT_O} \leq 0.3V$) as shown in Figure 8.

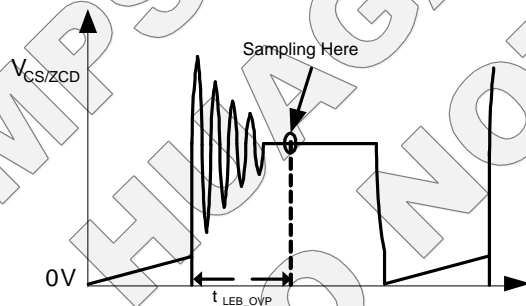

Figure 8: ZCD Voltage and OVP Sampler

Output Short-Circuit Protection

If an output short occurs, the ZCD can not detect the transformer's zero-current-crossing point, so the $190\mu s$ auto-restart timer triggers the power MOSFET's turn-on signal. Then the switching frequency of the power circuit drops to about

5kHz, and the output current is limited to its nominal current. The auxiliary-winding voltage drops to follow the secondary-winding voltage, V_{CC} drops to less than the UV threshold, and the system restarts. This sequence limits the output power and IC temperature rise if an output short occurs.

Primary-Side Over-Current Protection

The primary-side over-current protection prevents device damage caused by extremely excessive current, like primary winding short. If the CS/ZCD pin voltage rising to 2.5V at gate turn on interval, as shown in Figure 9, the primary-side over-current protection signal will be triggered and latched, the gate driver will be turned off and the IC works at quiescent mode, the V_{CC} voltage dropped below the UVLO which will make the IC shut down, and the system restarts again.

To avoid mis-trigger by the parasitic capacitances discharging when the MOSFET turns on, a LEB time is needed, this LEB time is relatively smaller than current regulation sensing LEB time, typical 280ns.

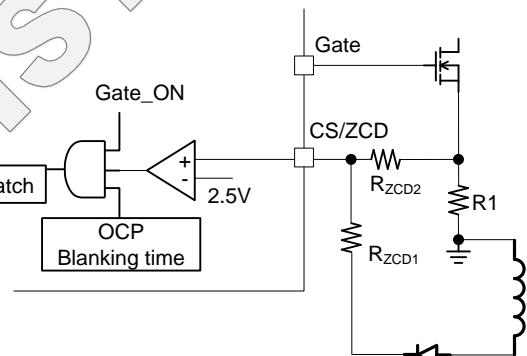

Figure 9: Primary-side OCP Sampling Unit

Brown-Out Protection

The MP4026 has brown-out protection: the internal peak detector detects the peak value of the rectified sinusoid waveform in MULT pin. If the peak value is less than the brown-out-protection threshold 0.3V for 36ms, the IC recognizes this condition as a brown-out, quickly drops the COMP voltage to zero, and disables the power circuit. If the peak value exceeds 0.4V, the IC restarts and the COMP voltage rises softly again. This feature prevents

both the transformer and LED currents from saturating during fast ON/OFF switching. Figure 10 shows the brown-out waveforms.

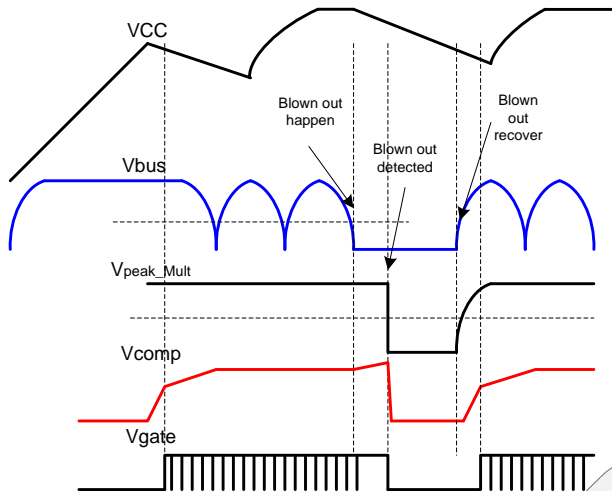

Figure 10: Brown-Out Protection Waveforms

IC Thermal Shut Down

To prevent from any lethal thermal damage, when the inner temperature exceeds the OTP threshold, the MP4026 shuts down switching cycle and latched until VCC drop below UVLO and restart again.

Design Example

For the design example, please refer to MPS application note AN076 for the detailed design procedure.

MPS CONFIDENTIAL
HUAGAO USE ONLY
DO NOT DISTRIBUTE

TYPICAL APPLICATION CIRCUITS

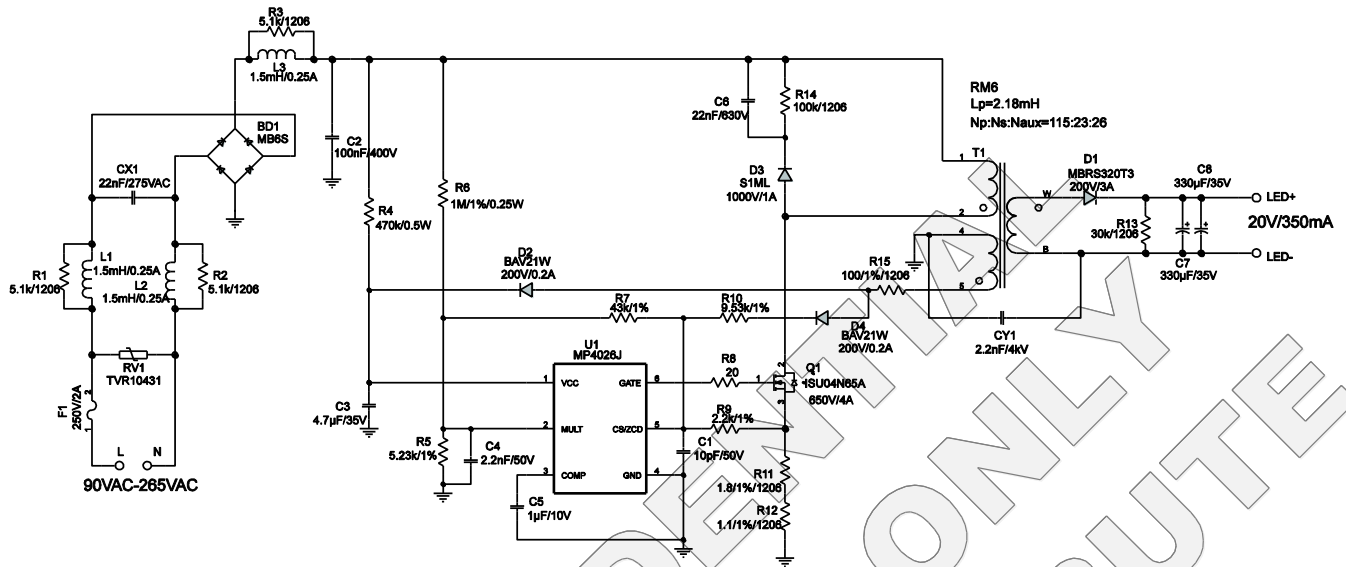
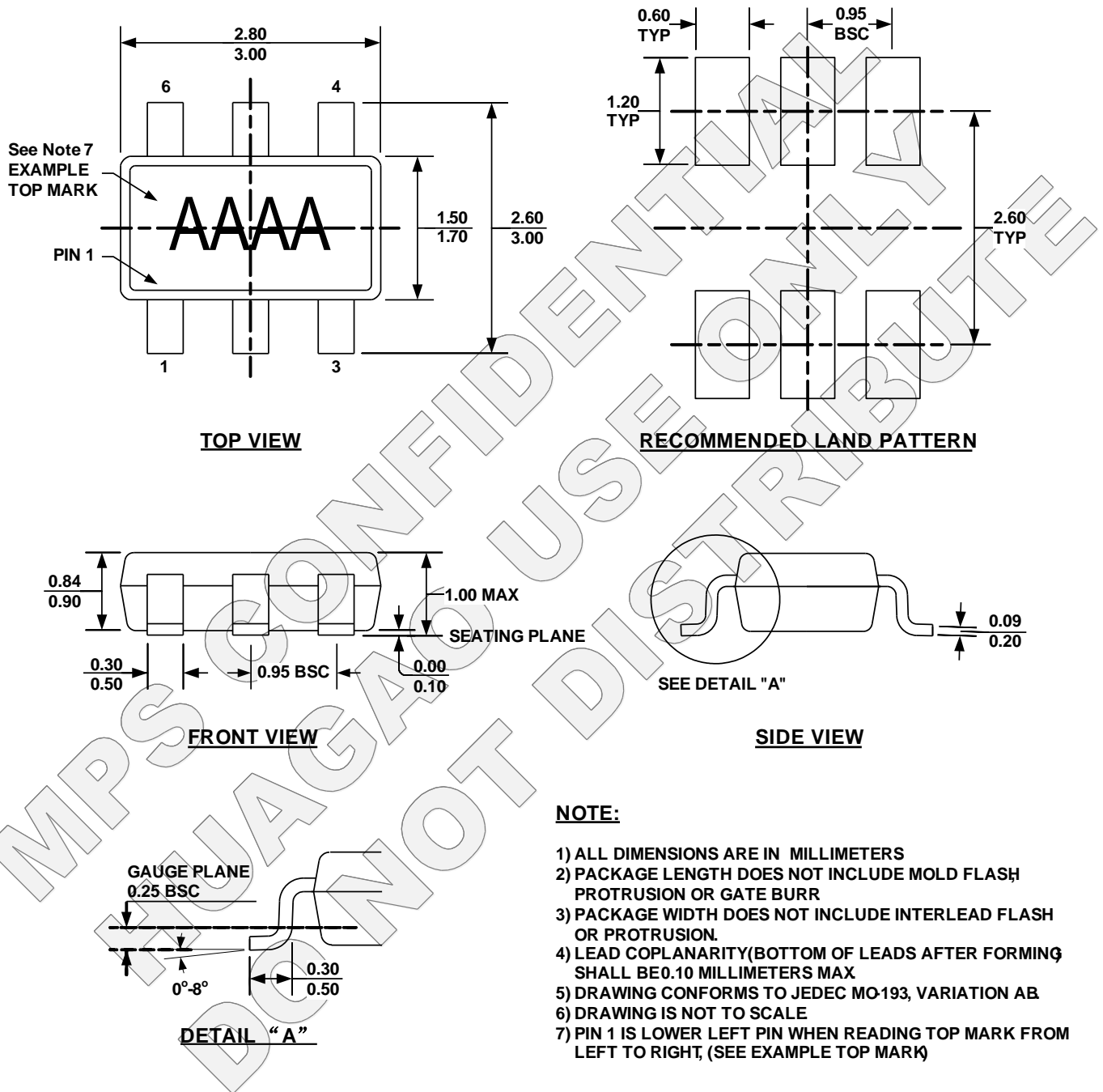

Figure 11: A19 Bulb Driver, 90-265VAC Input, Isolated Flyback Converter, $V_o = 20V$, $I_o = 350mA$
 EVB Model: EV4026-J-00A

PACKAGE INFORMATION

FCTSOT23-6



NOTICE: The information in this document is subject to change without notice. Users should warrant and guarantee that third party Intellectual Property rights are not infringed upon when integrating MPS products into any application. MPS will not assume any legal responsibility for any said applications.