

Features

- 100/120Vac input voltage applications
- Patented dimmable control technologies
- Supports Leading and Trailing edge dimmers
- Supports Multiple lamps in a parallel
- High power factor
- Low THDi
- Low BOM cost
- Fast Startup Time
- W/O aux-winding to Vcc
- Output Over Voltage Protection (OVP)
- Output Short Protection (OSP)
- Cycle by cycle Over-current Protection (OCP)
- Internal Over temperature Protection (OTP)
- Thermal Foldback Protection (TFP)
- SOP-8 Package

Description

AT8518 is a buck boost topology LED Driver integrated 500V MOS-FET for dimmable application. It has excellent performance with High power factor, low THDi and high efficiency. It can support leading and trailing edge dimmers and also multiple lamps in a parallel. AT8518 provides full range of protections with low BOM cost.

AT8518 uses Aitek Proprietary patented dimming technologies to make low component counts and high performance possible.

Application

- Triac Dimmable LED lamps
- Indoor Lighting

Typical Schematic

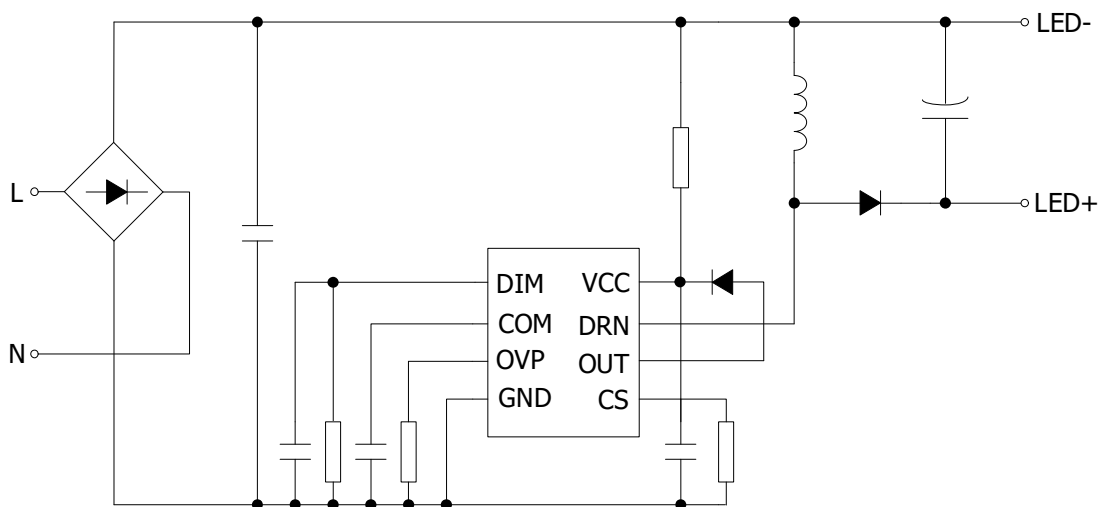

Ordering Information

Part Number	Package	MOQ
AT8518CS8R	SOP8	3K/Reel
AT8518DS8R	SOP8	3K/Reel
AT8518ES8R	SOP8	3K/Reel

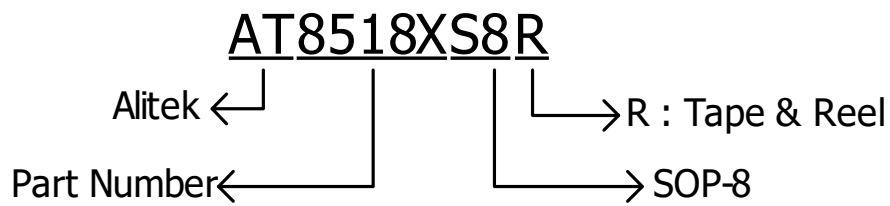

Pining Information

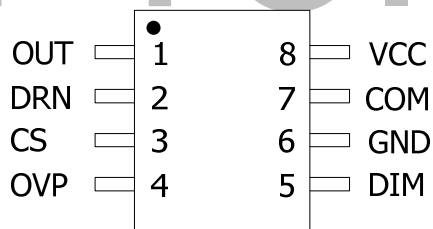

Pin	Symbol	Description
1	OUT	Connected Internal source of MOS
2	DRN	Drain of high side internal MOS
3	CS	Current sense Input
4	OVP	Setting OVP trigger voltage
5	DIM	Dimming control
6	GND	Ground
7	COM	Loop compensation
8	VCC	Supply Voltage

Function Block Diagram

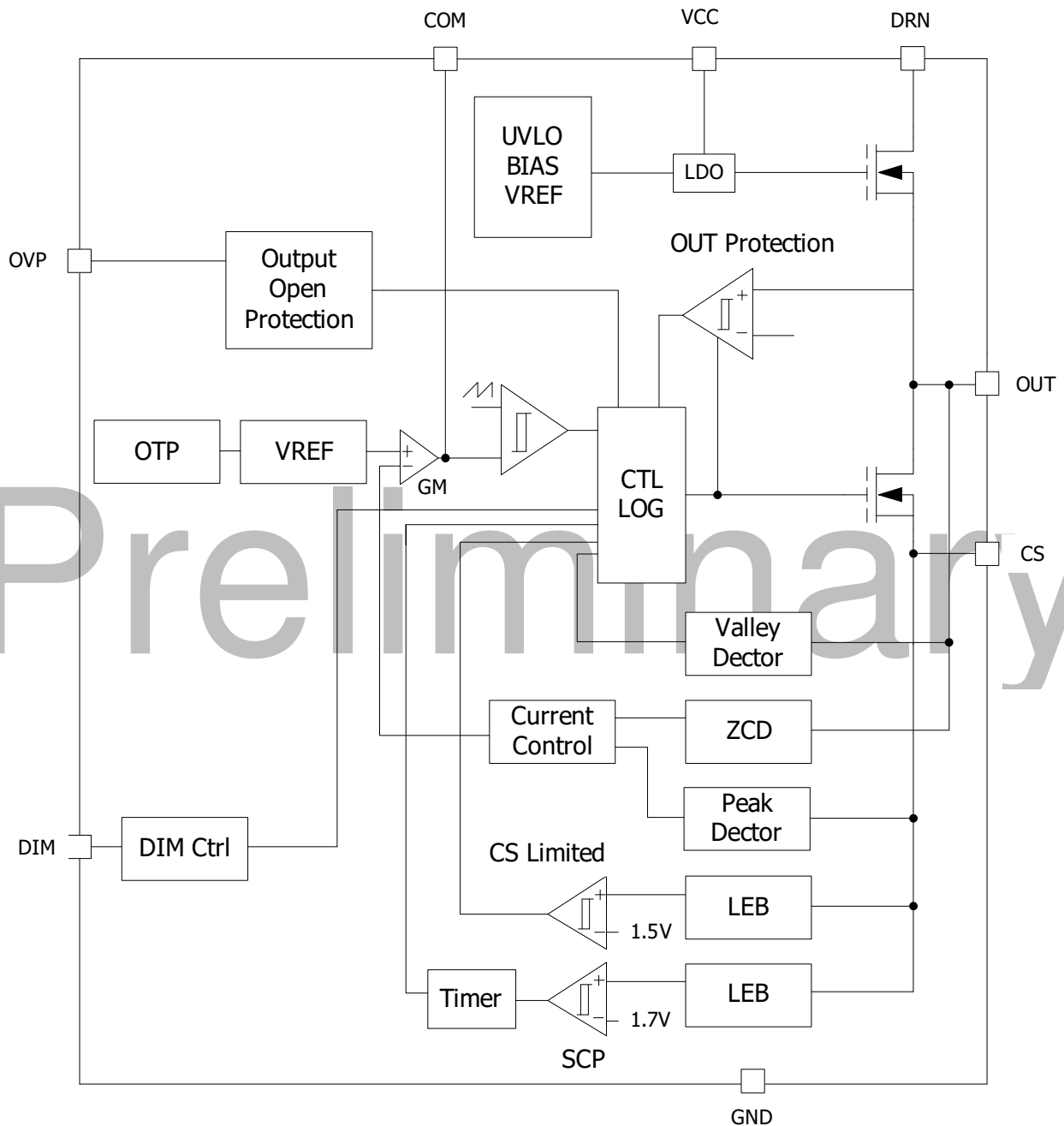

Absolute Maximum Ratings

Symbol	Definition	Min.	Max.	Units
V _{CC}	Supply Voltage	-0.3	17	V
V _D	Voltage on DRN pin	-0.3	500	
OVP	Voltage on OVP pin	-0.3	7.0	
V _{CS}	Voltage on CS pin			
V _{COMP}	Voltage on COMP pin			
T _J	Junction Temperature	-40	150	°C
T _{STG}	Storage Temperature	-60	150	
T _{LEAD}	Lead Temperature (Soldering 10Sec)		260	

Electronical Characteristics (V_{CC}= 15V, T_A = +25°C, unless otherwise noted)

Symbol	Parameter	Condition	Min	Typ	Max	Unit
--------	-----------	-----------	-----	-----	-----	------

Supply Voltage on Vcc Pin

I _{startup}	Start up Current		-	60	-	uA
I _{operating}	Operating Current	(Fosc=16kHz)	-	300	-	uA
UVLO _(on)	Turn-on threshold		11	12	13	V
UVLO _(off)	Turn-off threshold		5.5	6.5	7.5	V
V _{CCclamp}	VDD clamp voltage on Vcc Pin		14	15	16	V

Voltage Feedback on Sensing Pin

V _{CS}	Feedback reference voltage		294	300	306	mV
V _{ISEN_MAX}	Current limit reference voltage		1.4	1.5	1.6	V
I _{LEB}	Leading Edge Blanking Time		-	600	-	nS
V _{SCP}	SCP reference voltage		1.6	1.7	1.8	V
Ton _{min}	Min ON Time		-	610	-	nS

Loop Compensation on Comp pin

V _{st}	COMP start-up voltage		-	1	-	V
I _{SOURCE}	COMP Source Current		-	6	-	uA
G _m	Tran-Conductance	ΔI_COMP 30mV	-	20	-	uS
Ton _{max}	Max internal ON Time		-	18	-	us
Toff _{max}	Max internal OFF Time		-	90	-	us

Over Voltage Protection on ROVP pin

V _{ovp}	Reference ROVP voltage		0.4	0.5	0.6	V
TSH	OVP shutdown time		-	300	-	mS
T _{ovp}	OVP shutdown OFF Time	Rovp=100k and Vcs=300mV	-	11.2	-	us
V _{ovp_dis}	OVP shutdown disable threshold		90	100	110	mV

Driver on DRN pin

R _{ds_on}	R _{ds_on}		-	1.1	-	Ohm
V _{OUT_PRO}	OUT protection voltage	VCS<0.1V	-	1.1	-	V

Integrated MOS on DRN pin

V _{ds}			500	-	-	V
P/N	R _{ds_on}	AT8518CS8R	-	2.8	-	Ohm
		AT8518DS8R	-	5.7	-	
		AT8518ES8R	-	8	-	

OTP Protection on Chip

T _{Fold}	Foldback Temperature _(Note1)		-	140	-	°C
T _{SD}	Thermal shutdown		-	160	-	°C
ΔT _{SD}	Thermal shutdown hysteresis		-	60	-	°C

Note(1) : Design guaranteed, are not test in production

Vcc Pin

An UVLO comparator with hysteresis is implemented in AT8518. Once VCC rise up to UVLO_{on}, the internal blocks start to work. And it stops to work as VCC drops down to be lower than UVLO_{off}. The level of UVLO_{on} and UVLO_{off} are designed as 12V and 6.5V respectively as shown in Fig.1.

VCC capacitor is 1uF~4.7uF recommended.

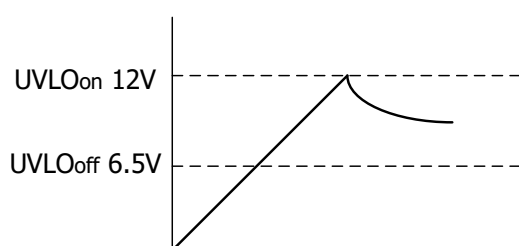

Fig.1

CS pin

In AT8518, the current of the MOSFET is detected through the current sense (CS) pin. If the level of CS pin is higher than V_{ISEN_MAX} level, the protection will be triggered to turn off the output driver. This cycle-by-cycle current limit function protects the system from being overload. And the V_{ISEN_MAX} level is 1.7V.

Output Short Protection on CS pin

Once the LED short-circuit condition occurs, System will work in minimum turn on time (600ns) and maximum turn off time (90us) condition which lower the overall energy to keep the system safe.

Comp Pin

Loop compensation on COMP pin. The capacitor is 0.1uF~1uF recommended.

Output Open Protection on OVP pin

To prevent system from being damaged, it can set a trigger level for protection.

If the output voltage rises up to a higher level than OVP trigger level programmed by an external resistor at OVP pin, the output driver will be turned off immediately to stop the switching and auto recovery by UVLO_{off} or TSH protection time finished.

Protection Mode

Protections mode are described in AT8518 as below Fig.2

Function	Protection Mode
OVP	Auto Recovery
Output Open	Auto Recovery
Output Short	Auto Recovery
Internal OTP	Auto Recovery

Fig.2

Thermal Foldback function

To prevent the system breaking down by high temperature, AT8518 sets T_{Fold} at +140°C typical. When the junction temperature is higher than +140°C, the output current will linearly decrease to 60% of maximum output current value and trigger over temperature protection(OTP) which will shut down the system. The system will recover when IC temperature reduce to 60°C (guaranteed by design).

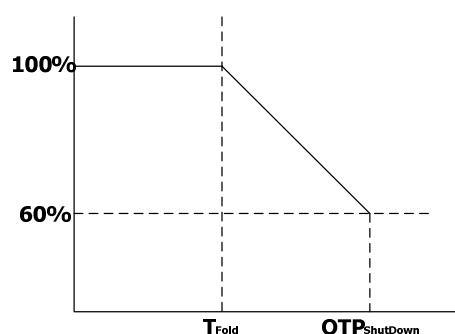
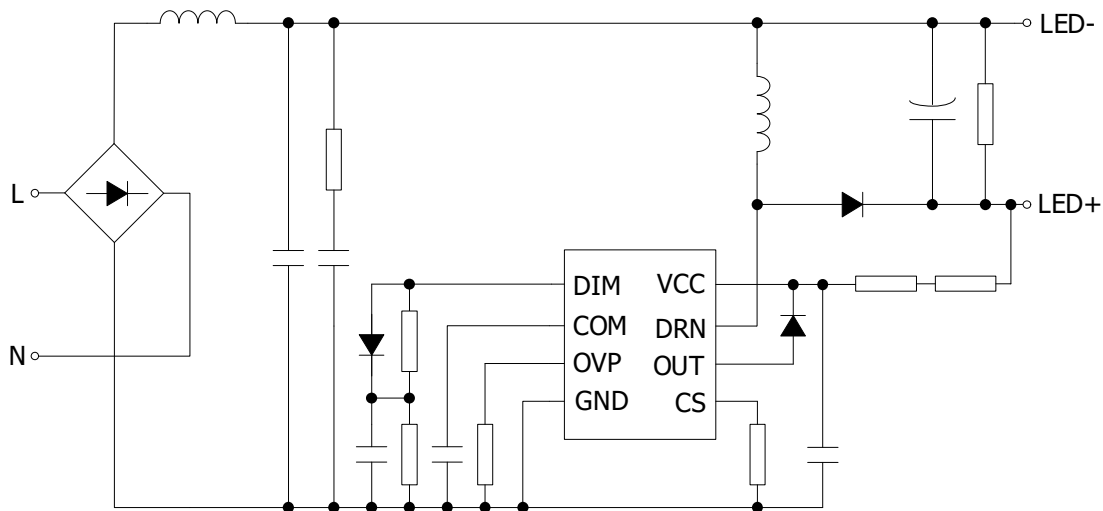

Fig.3

Application Information

60V/140mA application @120Vac



Preliminary

Package Information SOP-8

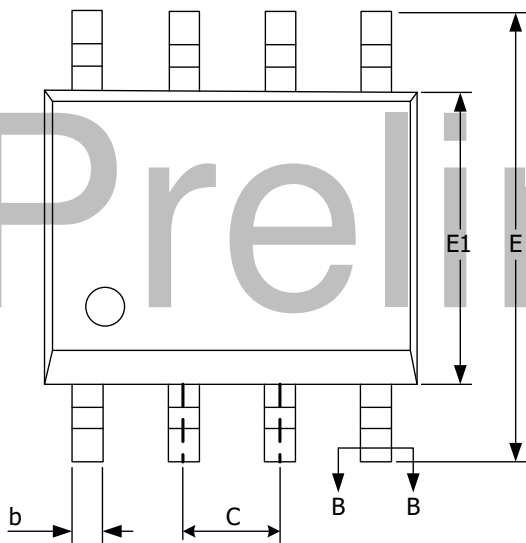
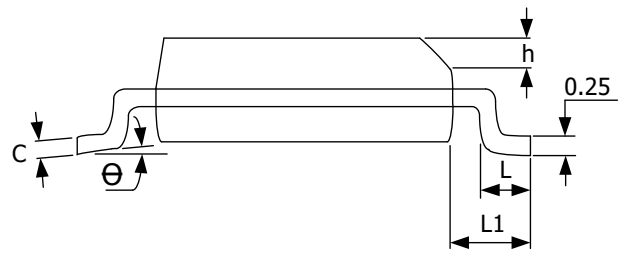
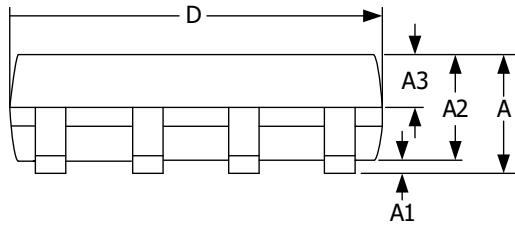

Preliminary

尺寸标示

Symbol	A	A1	A2	A3	b	b1	c	c1	D	E	E1	e	h	L	L1	θ
mm	-	0.100	1.3	0.6	0.39	0.38	0.21	0.19	4.7	5.8	3.7	1.27	0.25	0.5	1.05	0°
	1.75	0.225	1.5	0.7	0.48	0.43	0.26	0.21	5.1	6.2	4.1	BSC	0.50	0.8	BSC	8°