

### LED lighting Output Current Ripple Suppressor for Dimmable LED Constant Current System

**REV. P02**

*The values contained in this preliminary datasheet are for reference only and not for approval. Users should verify for a current and complete document before placing orders.*

#### General Description

The LD6802/J is an output current ripple suppressor for LED lighting. It supports easy use at output terminal with isolation or non-isolation active PFC architecture with constant current.

The LD6802/J is easy to achieve current ripple limitation with minimum output capacitance and built-in adjustable over voltage protection / multi-level over current protection and internal clamp Zener diode could be used at wide range LED voltage application. The device is the SOT-26 package to minimize the PCB size well as component counts.

#### Features

- Controller for adaptive 100Hz/120Hz current ripple remover
- Built-in clamping circuit for input voltage clamping
- 10V drive voltage for MOSFET control
- Programmable amplitude of LED current ripple
- Programmable maximum cathode voltage of LED
- Programmable maximum LED current
- Support wide output current variation
- Lamp short or open circuit protection
- Built-in internal over temperature protection
- SOT-26 Package

#### Applications

- LED Driver Application for Non-Ripple Current
- Analog Dimming LED power (Include TRIAC dimming system )

#### Typical Application

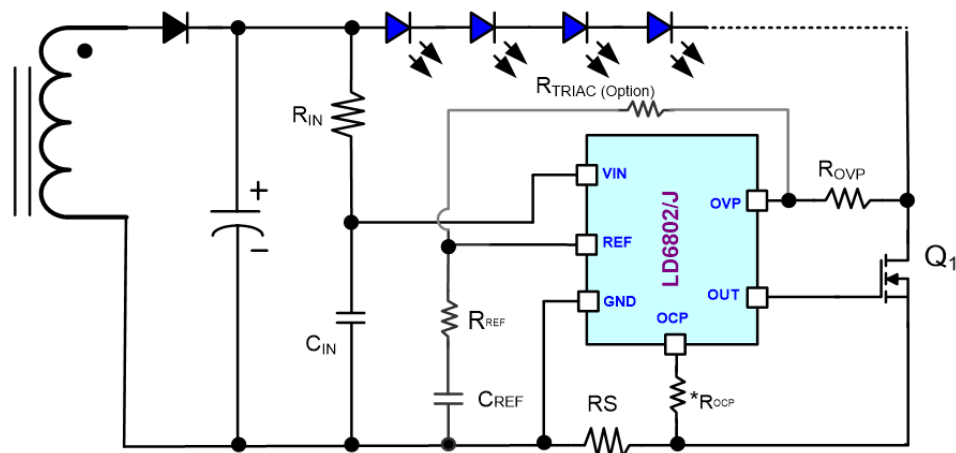

Note: Use  $R_{TRIAC (Option)}$  when TRIAC dimming system application

Figure.1 Reference Circuit Design

## Preliminary Datasheet LD6802/J

11/16/2018

### Pin Configuration

SOT-26 (TOP VIEW)

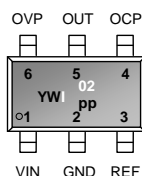

Y : Year code (D: 2004, E: 2005.....)  
W : Week code  
PP : Production code  
I02 : LD6802

SOT-26 (TOP VIEW)

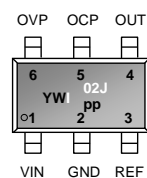

Y : Year code (D: 2004, E: 2005.....)  
W : Week code  
PP : Production code  
I02 : LD6802J

### Ordering Information

Part number	Package	Top Mark	Shipping
LD6802 GL	SOT-26	YWI/02	3000 /tape & reel
LD6802J GL	SOT-26	YWI/02J	3000 /tape & reel

The LD6802/J is ROHS compliant/green packaged.

### Protection Mode

Part number	Open LED Protection	Short LED Protection	Internal OTP
LD6802/JGL	Auto-recovery OUT pin is High	Auto-recovery Hiccup 250µs/250ms	Auto-recovery OUT pin is High

### Pin Descriptions

LD6802 Pin No.	LD6802J Pin No.	NAME	FUNCTION
1	1	VIN	Power Supply for the device. Internal Zener Clamp for wide range LED light bar voltage. Connecting a $R_{IN}$ to supply voltage source for current limit and a capacitor to GND for filter out noise
2	2	GND	Ground
3	3	REF	LED Reference Voltage, It's essential to connect REF pin with a ceramic capacitor to filter the 100/120Hz ripple.
4	5	OCP	LED current feedback and maximum LED current limit and source compensation current for low dimming operation.
5	4	OUT	This pin connects the MOSFET gate to regulate LED current ripple.
6	6	OVP	Over voltage Protection for Short LED protection

#### Block Diagram

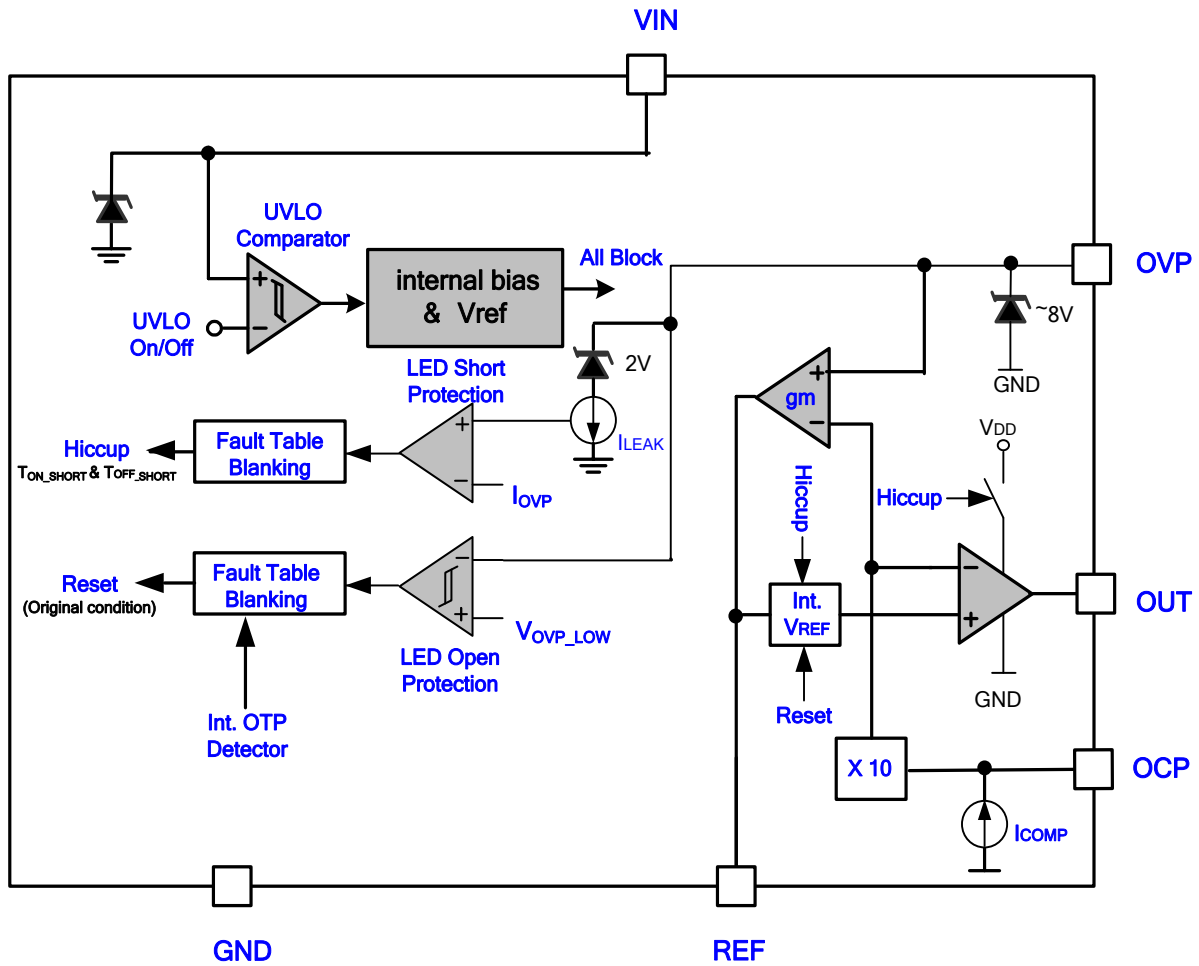

## Preliminary Datasheet LD6802/J

11/16/2018

### Absolute Maximum Ratings

VIN.....	-0.3V ~ 33V
VIN Shunt Regulation Pull-down Current .....	3mA
OVP.....	-0.3V ~ 8V
VIN Shunt Regulation Pull-down Current .....	1.5mA
OCP, OUT.....	-0.3V ~ 16V
REF.....	-0.3V ~ 6V
Maximum Junction Temperature.....	150°C
Storage Temperature Range.....	-65°C ~ 150°C
Package Thermal Resistance (SOT-26, $\theta_{JA}$ ).....	200°C/W
Power Dissipation (SOT-26, $T_J=125^\circ\text{C}$ , $T_a=85^\circ\text{C}$ ).....	200mW
Lead temperature (Soldering, 10sec).....	260°C
ESD Voltage Protection, Human Body Model.....	2.5KV
ESD Voltage Protection, Machine Model.....	250 V

#### Caution:

Stress exceeding maximum ratings may damage the device. Maximum ratings are stress ratings only. Functional operation above the recommended operating conditions is not implied. Extended exposure to stress above recommended operating conditions may affect device reliability.

### Recommended Operating Conditions

Item	Min.	Max.	Unit
Operating Junction Temperature <sup>Note3</sup>	-40	125	°C
VIN Operation Range	9	30	V
VIN Operation Current	0.5	2.5	mA
VIN pin Filter Capacitor	0.1	2.2	μF
REF pin Resistor to GND	0	5.1	kΩ
REF pin Capacitor to GND	0.22	1.5	μF
OCP pin Filter Resistance GND (*R <sub>OCP</sub> )	-	1	kΩ

Note :

- 1) Exceeding these ratings may damage the device.
- 2) This product guarantees robust performance from -20°C to 105°C ambient temperature. The junction temperature range specification is assured by design, characterization and correlation with statistical process controls.
- 3) When operation at harsh environment condition, as high temperature and humidity or climate change ...etc . Please pay attention to impedance variation between pin to pin or ground to avoid ripple remover closing loop and being failure.
- 4) When use dimmable power system by 0-10V or TRIAC dimmer, please consider \*R<sub>REF</sub>, \*C<sub>REF</sub>, \*R<sub>OCP</sub> design parameters.

### Electrical Characteristics

( $V_{IN}=15V$ ,  $T_A = 25^\circ C$  unless otherwise specified.)

PARAMETER	CONDITIONS	SYMBOL	MIN	TYP	MAX	UNITS
<b>Supply Voltage (VIN Pin)</b>						
Shunt Regulator Voltage	*; When shunt regulation pull-down current is ~2mA	$V_{IN\_CLAMP}$	29.0	30.5	32.0	V
Shunt Regulator Pull-Down Current	$V_{IN} = 33V$ , $R_{IN}=1K\Omega$	$I_{IN\_SINK}$		2	3	mA
Operating Current	$10V \leq V_{IN} \leq 27V$ ; $C_{OUT}=3000pF$	$I_{VIN}$		350		$\mu A$
UVLO(OFF)		$V_{UV\_OFF}$	4.5	5.5	6.5	V
UVLO(ON)		$V_{UV\_ON}$	6.5	7.5	8.5	V
<b>Gate Drive Output (OUT Pin)</b>						
Maximum Output voltage		$V_{OUT}$	4.5		12	V
GM	*;	G.M		5		$\mu A/V$
<b>CURRENT SENSE (OCP Pin)</b>						
Over Current Limited Threshold Voltage	After $V_{CC} \geq V_{UV\_ON}$	$V_{OCP\_LIM}$	0.3	0.4	0.5	V
Blanking time	*;	$T_{OCP\_LIM}$		100		ns
Recover Delay time	*; $V_{OUT}$ is Low Level	$T_{OCP}$		250		$\mu s$
LED Reference Voltage to LED Current rate	Ratio is $V_{REF}/V_{OCP}$	K	9.5	10	10.5	-
Maximum Output Current	When $V_{REF}=0V$	$I_{COMP\_MAX}$		13		$\mu A$
Enable Output Current by REF Voltage	Increase source current from 0 to $I_{COMP\_MAX}$	$V_{COMP\_L}$	1.2	1.3	1.4	V
<b>REFERENCE FILTER (REF Pin)</b>						
Startup Charging Current	When $UVLO(ON) \geq V_{IN} \geq V_{IN\_PRI}$	$I_{REF\_ST}$		0.45		mA
REF Regulation Operation Voltage	Normal operation mode	$V_{REF\_CLAMP}$	2.10	2.25	2.40	V
REF Max. Voltage	When Start mode and Protection mode	$V_{REF\_MAX}$	2.40		3.2	V
Internal REF Voltage when Short LED Protection is triggered	Here is de-bounce ~8 $\mu S$	$V_{REF\_SHORT}$	0.9	1.0	1.1	V

## Preliminary Datasheet LD6802/J

11/16/2018

( $V_{IN}=15V$ ,  $T_A = 25^{\circ}C$  unless otherwise specified.)

PARAMETER	CONDITIONS	SYMBOL	MIN	TYP	MAX	UNITS
<b>Over Voltage Protection (OVP pin)</b>						
Drain voltage of NMOSFET Threshold	When $R_{OVP}=100Kohm$	$V_{OVP\_DRAIN}$	7.0	8.0	9.0	V
Short LED Protection Sink Current		$I_{OVP}$	52	60	68	$\mu A$
Short LED Protection Delay Time	*	$T_{ON\_SHORT}$	140	280	420	$\mu s$
Short LED Protection Reset Time	*	$T_{OFF\_SHORT}$	140	280	420	ms
LED Open Protection Threshold Voltage		$V_{OVP\_LOW}$	2	8	15	mV
LED Open Protection Voltage Hysteresis		$V_{OVP\_HYS}$	8	12	15	mV
LED Open Protection Trigger De-bounce	*	$T_{OVP\_LOW}$		40		ms
<b>Internal Over Temperature Protection</b>						
OTP Trip level	*	OTP		140		$^{\circ}C$
OTP Hysteresis	*	$\Delta OTP$		40		$^{\circ}C$

\*: Guaranteed by Design.

#### Application Information

##### Basic Description

LD6802/J is an external MOSFET controller for LED lighting current ripple eliminated. The REF pin connection a filter capacitor to GND to suppressor the 100/120Hz LED current ripple. In the start-up process, the LD6802/J charges the REF capacitor quickly to avoid LED voltage overshoot this time. And the device provide adjustable short LED string protection, LED string open protection and programmable over current limiting.

##### Theory of Operation

The LED light bar and LD6802/J are both supplied by an AC/DC current source. The drain of external MOSFET is connected to the cathode of LED light bar. A sensing resistor  $R_{OCP}$  is connected between the source of MOSFET and GND. The gate is connected to the OUT pin of LD6802/J.

The LD6802/J detects the OVP pin and OCP pin voltage to adjust  $V_{REF}$  Voltage and control the external MOSFET operate in linear/saturation region. When external MOSFET working in the saturation region, the LED current ripple transfer to LED voltage on MOSFET. If the drain Voltage of external MOSFET break away saturation region, the LED current ripple suppressor will invalid naturally.

##### Reference Voltage to LED Current Ratio and LED Current Limit

The  $V_{REF}$  is regulation the LED current to limit threshold. The  $V_{REF}$  operation voltage is limited to 2.25V around on REF pin. So that the LED limit current threshold voltage is

$$V_{REF} \cong K \times (I_{LED} \times R_s) = K \times V_{OCP\_REG}$$

The suggestion for normal LED operation current is

approach 50% of LED limit current threshold (Normally,  $V_{REF}$  is 1.0~1.3V). It avoids the larger LED peak current to trigger over current limit protection on OCP pin ( $V_{OCP\_LIM} \cong 0.40V$ ) or produce MOSFET over current issue as short output circuit. Then setting REF pin voltage must be higher than output ripple voltage for real LED lamp. The equation is

$$V_{REF} \geq (V_{LED,P-P} \div 2) + (R_{ON\_MOS} \times I_{LED,MEAN})$$

Where  $V_{LED,P-P}$  is a ripple voltage of LED lamp between output terminal to ground,  $R_{ON\_MOS}$  is turn on resistance of MOSFET,  $I_{LED,MEAN}$  is an average current of LED lamp.

##### LED String Open Protection

When OVP pin voltage is under about  $V_{OVP\_LOW}$  and  $T_{OVP\_LOW}$  de-bounce time, the LD6802/J will go to LED open protection stage. This time OUT pin and  $V_{REF}$  voltage pull high until the LED string replies connection. If OVP pin voltage is higher than 30mV around, LD6802/J will be into saturation region and enable ripple remover function .

##### LED string Short Protection

If OVP pin voltage larger than 2V and in condition of  $I_{OVP} \geq 60\mu A$  and continuous  $T_{ON\_SHORT}$  around, the LD6802/J would be change REF limit voltage to 1.0V and turn off MOSFET until  $T_{OFF\_SHORT}$ . Then, the over voltage protection state is reset. The programed over voltage protection calculated as below:

$$V_{OVP\_TH} = 2V + (R_{OVP} \times 60\mu A)$$

Where  $V_{OVP\_TH}$  is Drain voltage of MOSFET.

##### LED Current Limit

The voltage of OCP pin is limited to 0.40V internally. So the current of MOSFET limitation is  $0.40V/R_{OCP}$ . Current limit can protect the FET and current resistor when LED is short connected or HOT-PLUG. The function of

current limit is higher priority than drain voltage limit. It means that the voltage on drain of MOSFET is not limited when LED current exceed current limit threshold.

#### Shunt Regulation Voltage and Current on VIN pin

The LD6802/J support wide range LED light bar application that integrated Zener diode ( $V_{IN\_CLAMP} \sim 30V$ ) which is about 2.5 mA sink current and  $V_{UV\_ON}$  is to 7.5V.

So the value of  $R_{IN}$  that is connected between  $V_{LED}$  and  $V_{IN}$  of LD6802/J, we can be calculated as below:

$$R_{IN} \leq (V_{LED\_MIN} - V_{UV\_ON}) \div 0.5mA$$

$$\text{and } R_{IN} \geq (V_{LED\_OPEN} - V_{IN\_CLAMP}) \div 2.5mA$$

Where  $V_{LED}$  is a terminal voltage of LED lamp or auxiliary wire

#### Internal Thermal protection

Thermal protection limits total power dissipation in this device. When the junction temperature reaches  $\sim 140^{\circ}C$  approximately, the LD6802/J will turn on the MOSFET completely until the IC's junction temperature cools down approximately  $\sim 40^{\circ}C$ .

#### PCB Design Guideline

1. The bypass capacitor of  $V_{IN}$  should be placed as close as possible to the  $V_{IN}$  and GND pin of LD6802/J.
2. The filter capacitor of  $C_{REF}$  should be placed as close as possible to the REF and GND pin of LD6802/J.
3. LD6802/J Controller should be placed near to the external MOSFET.
4. To consider temperature requirement, we need add PCB pad or heat sink be to fit system specification.

5. The area of LED current loop should be as small as possible



#### LD6802/J design guide

Example:

System Parameter	Specification	System Parameter	Specification
V <sub>LED+</sub>	20~60Vdc	I <sub>LED</sub>	700mA+/-5%
V <sub>LED+_OVP</sub>	72Vdc	I <sub>LED_RIPPLE</sub>	< 10%
V <sub>LED+_P-P</sub>	~2.0V		

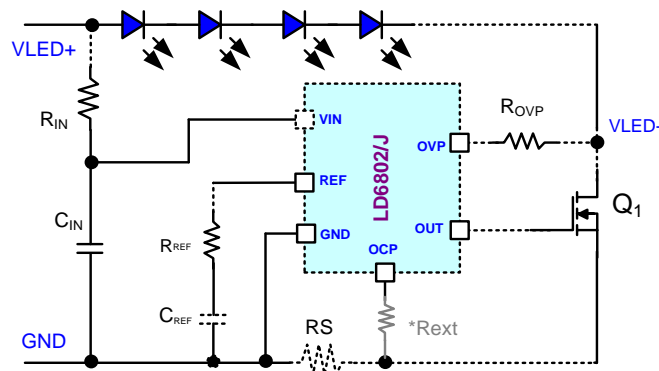

1. Base on the 30V zener integrated and the 7.5V VIN start threshold, the value of R<sub>VIN</sub> may satisfy the following conditions:

$$\frac{72V - 30V}{2.5mA} \leq R_{IN} \leq \frac{20V - 7.5V}{0.5mA}$$

So, R<sub>IN</sub> is recommend to 16.8kΩ~25KΩ. And C<sub>IN</sub> value is recommend 0.1μF~1μF

2. The maximum voltage of REF pin is ~2.25V in order to limit the maximum output current especially in the short circuit condition. The value of R<sub>OCP</sub> can be calculated as below:

$$(2.25V \times 0.8) \geq V_{REF} \geq (2.0V \div 2) + (R_{ON\_MOS} \times I_{LED})$$

$$\text{So } V_{REF} \approx 1.0 \sim 1.3V$$

So, R<sub>OCP</sub> is recommend to 0.14~0.19Ω.

3. When the voltage of LED- reaches V<sub>OVP</sub> which is set by the R<sub>OVP</sub>, LD6802/J pulls down the VIN then turns off the MOSFET. In order to ensure nothing will be damaged in the short circuit condition, the value of R<sub>OVP</sub> must satisfy the following conditions:

$$V_{LED\_OPEN} - V_{LED\_MAX} < V_{OVP\_TH} < V_{LED\_OPEN} - V_{LED\_MIN}$$

$$V_{OVP\_TH} = 2V + (60\mu A \times R_{OVP})$$

As this example , R<sub>OVP</sub> is recommend to 150k~820kΩ.

- The value of the capacitor between  $V_{REF}$  and GND can determine the final amplitude of the current ripple. It should be large enough in order to remove the current ripple of the LED string. However, too large capacitor may slow down the dynamic response. In normal condition,  $0.22\mu\text{F}$  to  $2.2\mu\text{F}$  on REF pin is relatively reasonable.
- To ensure LD6802/J work properly, the  $R_{DS\_ON}$  of MOSFET must be less than  $250\text{m}\Omega$  at  $V_{GS} = 5\text{V}$ . The MOSFET will endure a large power shorting the output on the moment, so the appropriate package and  $R_{DS\_ON}$  of the MOSFET is necessary. Our suggestion is the below table.

$I_{LED}$ (mA)	$V_{th}$ (V) of MOSFET	$R_{DS\_ON}$ (m $\Omega$ ) of MOSFET at $V_{th}=7.5\text{V}$	$BVDSS$ (V) of MOSFET
$\cong 350$	2~4	< 250	1.2 x Open Circuit Clamp Voltage ( $V_{LED\_OPEN}$ )
$350 < I_{LED} \leq 500$		< 200	
$500 < I_{LED} \leq 1000$		< 100	
$1000 < I_{LED} \leq 1500$		< 50	

- When short the LED lamp, there is an overshoot on the drain of the MOSFET. The breakdown voltage of the MOSFET must be higher than  $V_{OVP}$ . A diode connected to LED+&LED- can reduce the overshoot when Short.

#### Package Information

SOT-26

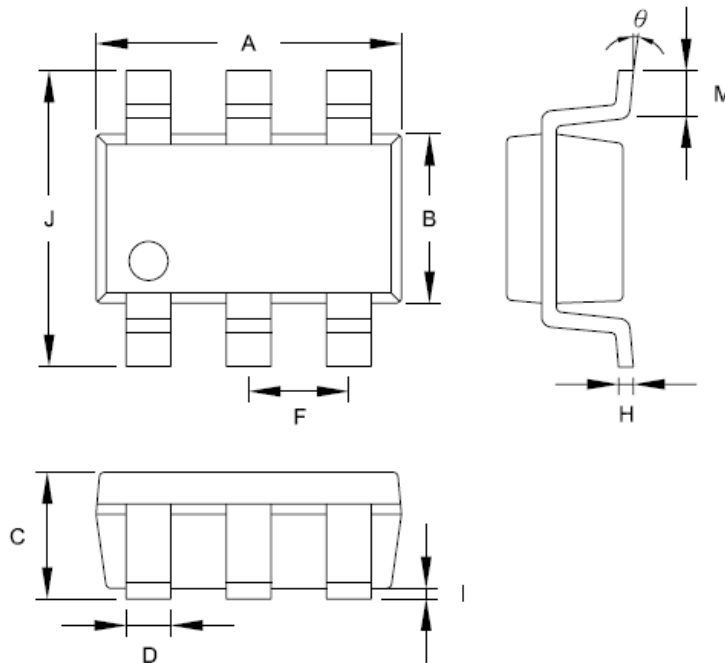

Symbol	Dimension in Millimeters		Dimensions in Inches	
	Min	Max	Min	Max
A	2.692	3.099	0.106	0.122
B	1.397	1.803	0.055	0.071
C	-----	1.450	-----	0.057
D	0.300	0.500	0.012	0.020
F	0.95 TYP	0.037 TYP		
H	0.080	0.254	0.003	0.010
I	0.050	0.150	0.002	0.006
J	2.600	3.000	0.102	0.118
M	0.300	0.600	0.012	0.024
θ	0°	10°	0°	10°

#### Important Notice

Leadtrend Technology Corp. reserves the right to make changes or corrections to its products at any time without notice. Customers should verify the datasheets are current and complete before placing order.

## **Preliminary Datasheet** **LD6802/J**

11/16/2018

### **Revision History**

REV.	Date	Change Notice
P00	06/26/2018	Original specification
P01	09/16/2018	1. Modify some parameters, as $V_{OCP\_LIM}$ , $V_{COMP\_L}$ , $I_{REF\_ST}$ , $V_{REF\_CLAMP}$ , $V_{REF\_MAX}$ , $V_{REF\_SHORT}$ for dimming performance and protector function. 2. Add LD6802/J design guide.
P02	11/16/2018	1. Modify some parameters for LED short / open protection. 2. Add a new product name of LD6802/JGL. 3. Modify application note.