

AC/DC Advanced Digital Power Controller for Single-Stage Dimmable LED Drivers

1.0 Features

- Isolated/non-isolated off-line 120V_{AC}/230V_{AC} LED driver up to 20W output power
- Wide line frequency range (from 45Hz to 66Hz)
- Meets IEC61000-3-2 current harmonic requirement
- Total harmonic distortion < 20% with PF > 0.92
- Excellent dimmer compatibility
 - » Leading-edge dimmer
 - » Trailing-edge dimmer
 - » Digital smart dimmer
- Wide dimming range of 1% to 100%
- Intelligent digital control integrating current sink function into power switching circuit
- Advanced IC power management and voltage sensing enables the use of off-the-shelf inductor
- Resonant control to achieve high efficiency (typical > 85% without dimmer)
- Excellent AC line distortion immunity ensures quality of product under real-life circumstances
- Over-temperature LED current foldback and shutdown
- Tight LED current regulation ($\pm 5\%$)
- Fast start-up (< 0.5s without dimmer)
- Multiple protection features that include:
 - » LED open-circuit and short-circuit protection
 - » Current sensing resistor open circuit and short-circuit protection
 - » AC line over-voltage protection
 - » Over-current protection



2.0 Description

The iW3688 is a single-stage, high-performance AC/DC off-line power supply controller for dimmable LED luminaires. It applies advanced digital control technology to detect the dimmer type, enabling it to provide dynamic impedance to interface with the dimmer and to control the LED brightness at the same time.

With advanced dimmer detection technology, the iW3688 can operate with most wall dimmers including leading-edge dimmers (R-type or R-L type), trailing-edge dimmers (R-C type), and smart dimmers. In addition, the iW3688's cycle-by-cycle waveform analysis technology allows for fast dimmer transient response.

In no-dimmer mode, the iW3688 operates the main power converter that delivers current to the LED load in quasi-resonant mode to provide high power efficiency and low electro-magnetic interference (EMI). When there is no dimmer on the line, the iW3688 optimizes the power factor and minimizes the current harmonic distortion to the AC line. The commonly utilized converter topologies for iW3688 are buck-boost and flyback.

The iW3688 uses patented PrimAccurate™ primary-side sensing technology to achieve excellent LED current regulation under different AC line and LED load voltages, without using a secondary-side feedback circuit and thus eliminating the need for an opto-coupler.

The iW3688 minimizes the external components count by simplifying the EMI filter with Dialog's EZ-EMI® technology, and by integrating current sink, switching, and V_{CC} charging circuit. Additionally, the iW3688 does not require an auxiliary winding, which eliminates the need for a custom inductor. The digital control loop of the iW3688 maintains stability over all operating conditions without the need for loop compensation components.

The iW3688 maintains high performance wide-range dimming and achieves excellent dimmer compatibility with a simple application circuit.

3.0 Applications

- Dimmable LED retrofit lamps up to 20W
- Dimmable LED luminaires up to 20W

AC/DC Advanced Digital Power Controller for Single-Stage Dimmable LED Drivers

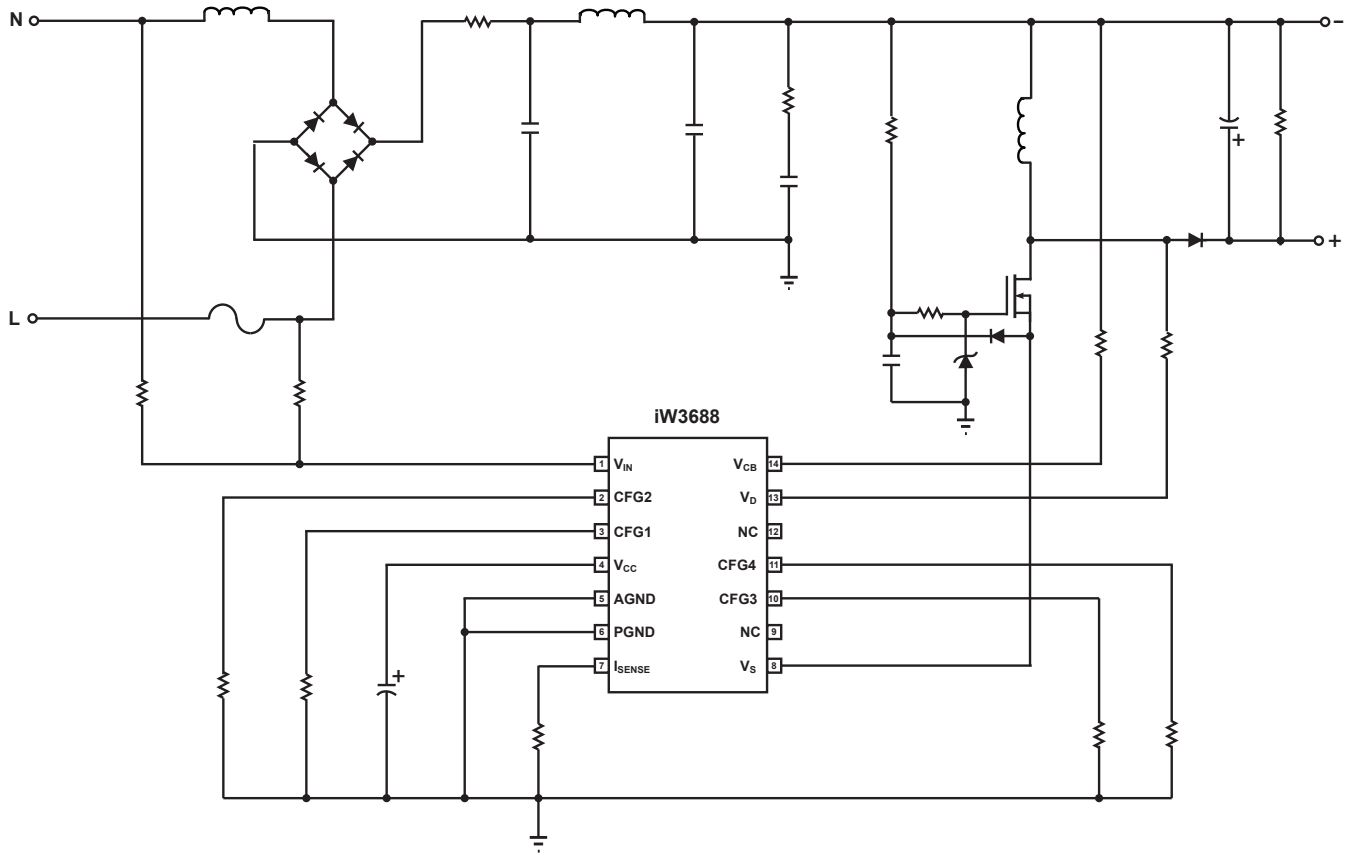

Figure 3.1: iW3688 Simplified Application Circuit

AC/DC Advanced Digital Power Controller for Single-Stage Dimmable LED Drivers

4.0 Pinout Description

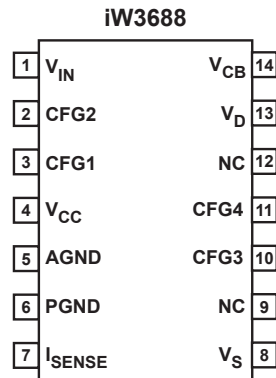

Figure 4.1: 14-Lead SOIC-14 Package

Pin #	Name	Type	Pin Description
1	V _{IN}	Analog Input	Rectified AC line voltage input.
2	CFG2	Analog Input	Used for dimming mode configuration. See the applications section for additional information.
3	CFG1	Analog Input	Configures OTP threshold on start-up. See the applications section for configuration information.
4	V _{CC}	Power	Power supply for control logic.
5	AGND	Ground	Signal ground. It should be connected to the power ground on PCB.
6	PGND	Ground	Power ground.
7	I _{SENSE}	Analog Input	Current sense.
8	V _S	Analog Input	Source voltage of MOSFET.
9	NC	No Connection	Not internally connected.
10	CFG3	Analog Input	Used for dimming mode configuration. See the applications section for additional information.
11	CFG4	Analog Input	Used for dimming mode configuration. See the applications section for additional information.
12	NC	No Connection	Not internally connected.
13	V _D	Analog Input	Drain voltage of MOSFET.
14	V _{CB}	Analog Input	Input capacitor voltage after EMI filter.

AC/DC Advanced Digital Power Controller for Single-Stage Dimmable LED Drivers

5.0 Absolute Maximum Ratings

Absolute maximum ratings are the parameter values or ranges which can cause permanent damage if exceeded. For maximum safe operating conditions, refer to Section 6.0 Electrical Characteristics.

Parameter	Symbol	Value	Unit
DC supply voltage range (pin 4)	V_{CC}	-0.3 to 6	V
V_{IN} input (pin 1)		-0.3 to 6	V
CFG1 input (pin 3)		-0.3 to 6	V
CFG2 input (pin 2)		-0.3 to 20	V
I_{SENSE} input (pin 7)		-0.3 to 6	V
V_S input (pin 8)		-0.3 to 20	V
CFG3 input (pin 10)		-0.3 to 6	V
CFG4 input (pin 11)		-0.3 to 20	V
V_D input (pin 13)		-0.3 to 6	V
V_{CB} input (pin 14)		-0.3 to 6	V
Power dissipation at $T_A \leq 25^\circ\text{C}$		TBD	mW
Maximum junction temperature	T_{JMAX}	150	$^\circ\text{C}$
Operating junction temperature	T_{JOPT}	-40 to 150	$^\circ\text{C}$
Storage temperature	T_{STG}	-65 to 150	$^\circ\text{C}$
Thermal Resistance Junction-to-Ambient [Still Air]	Ψ_{JB}	45	$^\circ\text{C}/\text{W}$
ESD rating per JEDEC JESD22-A114		$\pm 2,000$	V
Latch-up test per JESD78A		± 100	mA

AC/DC Advanced Digital Power Controller for Single-Stage Dimmable LED Drivers

6.0 Electrical Characteristics

$V_{CC} = 5V$, $-40^{\circ}C \leq T_A \leq 85^{\circ}C$, unless otherwise specified (Note 1)

Parameter	Symbol	Test Conditions	Min	Typ	Max	Unit
V_{IN} SECTION						
Start-up voltage threshold	$V_{IN(ST)}$ (Note 2)	$T_A = 25^{\circ}C$, pulse width $\geq 500\mu s$		0.4		V
Over-voltage shutdown threshold -00/-20	$V_{IN(OVP)}$ (Note 2)	$T_A = 25^{\circ}C$	1.582	1.758		V
Over-voltage shutdown threshold -01/-21	$V_{IN(OVP)}$ (Note 2)	$T_A = 25^{\circ}C$	1.512	1.68		V
V_{IN} scaling resistance	Z_{VIN} (Note 3)	After start-up	2.425	2.5	2.575	k Ω
V_{IN} sampling range	V_{IN} (Note 2)	After start-up	0		1.8	V
Line frequency range	f_{IN}		45		66	Hz
V_D/V_{CB} SECTION						
Maximum V_D input current	$I_{IN(VD)}$				750	μA
Maximum V_{CB} input current	$I_{IN(VCB)}$				750	μA
V_{OUT} sensing resistor	R_{VSENSE}			25		k Ω
Output Over-Voltage Protection (OVP) threshold	$V_{SENSE(OVP)}$	$T_A = 25^{\circ}C$, negative edge		1.8		V
Output nominal threshold	$V_{SENSE(NOM)}$	$T_A = 25^{\circ}C$, negative edge		1.5		V
Output Under-Voltage Protection (UVP) threshold	$V_{SENSE(UVP)}$	$T_A = 25^{\circ}C$, negative edge		0.3		V
Source Switch SECTION						
Input leakage current (V_S pin)	$I_{BVS(VS)}$	$T_A = 25^{\circ}C$		TBD		μA
Internal switching MOSFET ON-resistance	$R_{DS(ON)}$	$I_{SINK} = 1A$, $T_A = 25^{\circ}C$		0.2	TBD	Ω
Maximum switching frequency (Note 4)	$f_{SW(MAX)}$			90		kHz
Maximum sinking current	$I_{PK(CS)}$	$V_S = 12V$		269		mA

AC/DC Advanced Digital Power Controller for Single-Stage Dimmable LED Drivers

6.0 Electrical Characteristics (cont.)

$V_{CC} = 5V$, $-40^{\circ}C \leq T_A \leq 85^{\circ}C$, unless otherwise specified (Note 1)

Parameter	Symbol	Test Conditions	Min	Typ	Max	Unit
V_{CC} SECTION						
Operating voltage	V_{CC}			5	5.8	V
Start-up threshold	$V_{CC(ST)}$		4.8	5	5.3	V
Under-voltage lockout threshold	$V_{CC(UVL)}$		3.9	4	4.1	V
V_{CC} high threshold	$V_{CC(HIGH)}$			5.5		V
Operating current	I_{CCQ}			TBD		mA
I_{SENSE} SECTION						
I_{SENSE} short protection reference	V_{RSENSE}			0.16		V
Over-current limit threshold	V_{OCP}			1.3		V
Configuration SECTION						
CFG1–CFG4 pin configuration current	$I_{CFG(CFG)}$		95	100	105	μA
Temperature Derating and Over-Temperature Protection SECTION						
Shutdown threshold	$T_{OTP(START)}$			150		$^{\circ}C$

Notes:

- Note 1. Adjust V_{CC} above the start-up threshold before setting at 5V.
- Note 2. Refer to the voltage level at the V_{IN_A} point in Figure 8.1. The typical impedance between the V_{IN} pin and V_{IN_A} point is 500 Ω .
- Note 3. Refer to Z_{VIN} in Figure 8.1.
- Note 4. Operating frequency varies based on the line and load conditions. See the Theory of Operation section (Section 9.0) for more details.

AC/DC Advanced Digital Power Controller for Single-Stage Dimmable LED Drivers

7.0 Typical Performance Characteristics

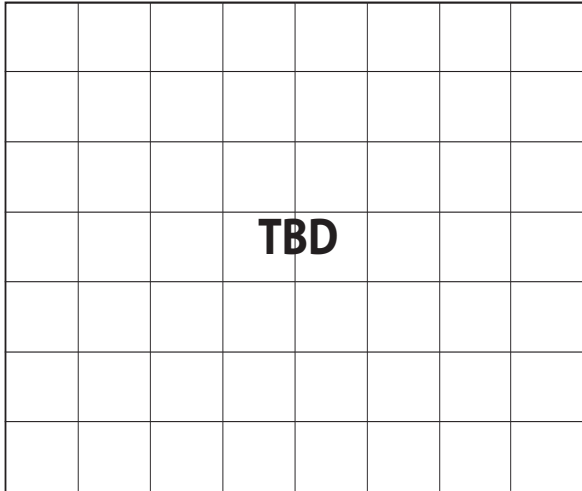

Figure 7.1 : V_{CC} vs. V_{CC} Supply Start-up Current

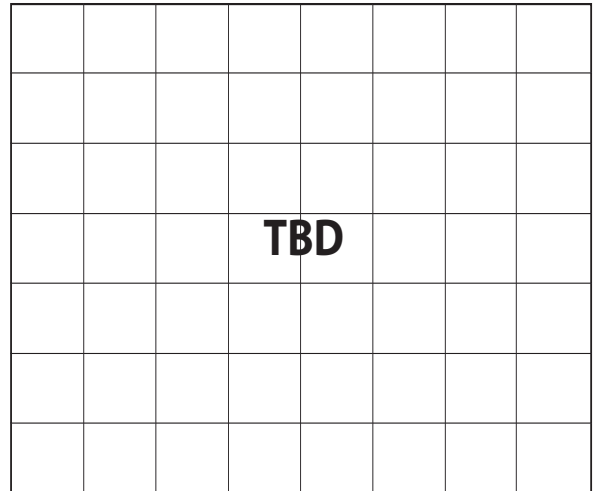

Figure 7.2 : V_{CC} Start-Up Threshold vs. Temperature

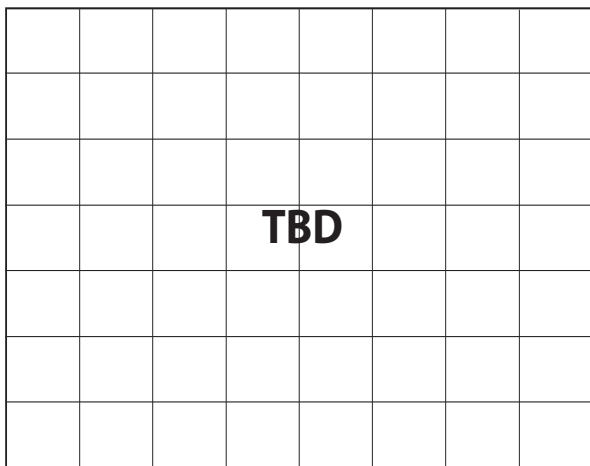

Figure 7.3 : % Deviation of Switching Frequency to Ideal Switching Frequency vs. Temperature

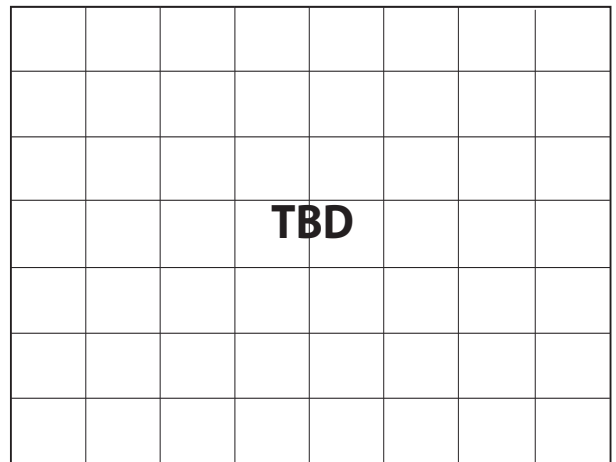

Figure 7.4 : Internal Reference vs. Temperature

AC/DC Advanced Digital Power Controller for Single-Stage Dimmable LED Drivers

8.0 Functional Block Diagram

The Digital Core (shown in figure 8.1) analyzes the rectified AC waveform and determines whether a dimmer is connected on the line. There are three dimmer modes in the iW3688: no-dimmer, leading-edge dimmer, and trailing-edge dimmer. Based on the detected dimmer type and input voltage waveform, the iW3688 determines whether the iW3688 is operating in current sink mode or switching mode. During switching mode, the output current regulation is determined by inductor peak current (I_{SENSE} pin), the magnetic flux status of the inductor (V_D and V_{CB} pins), and the input voltage waveform (V_{IN} pin) (refer to section 9.4 for more information).

If no dimmer is detected on the AC line, the iW3688 operates in no-dimmer mode where only the switching circuit is enabled. In this mode, the average output current

is regulated to the nominal value and is immune to input voltage variation.

If a dimmer (either leading-edge or trailing-edge) is detected on the AC line, the iW3688 operates in dimmer mode. In dimmer mode, MOSFET (Q1 in Figure 11.1) operates in both switching mode and current sink mode based on the timing control of iW3688. During the switching mode, the output current is adjusted based on the detected phase conduction angle. During current sink mode, the switching circuit is disabled and the current sink circuit is enabled. The main MOSFET is forced to operate in linear mode, where the current through MOSFET is regulated by the Digital Core. As shown in Figure 8.1, V_{CC} can be charged during both current sink mode and switching mode.

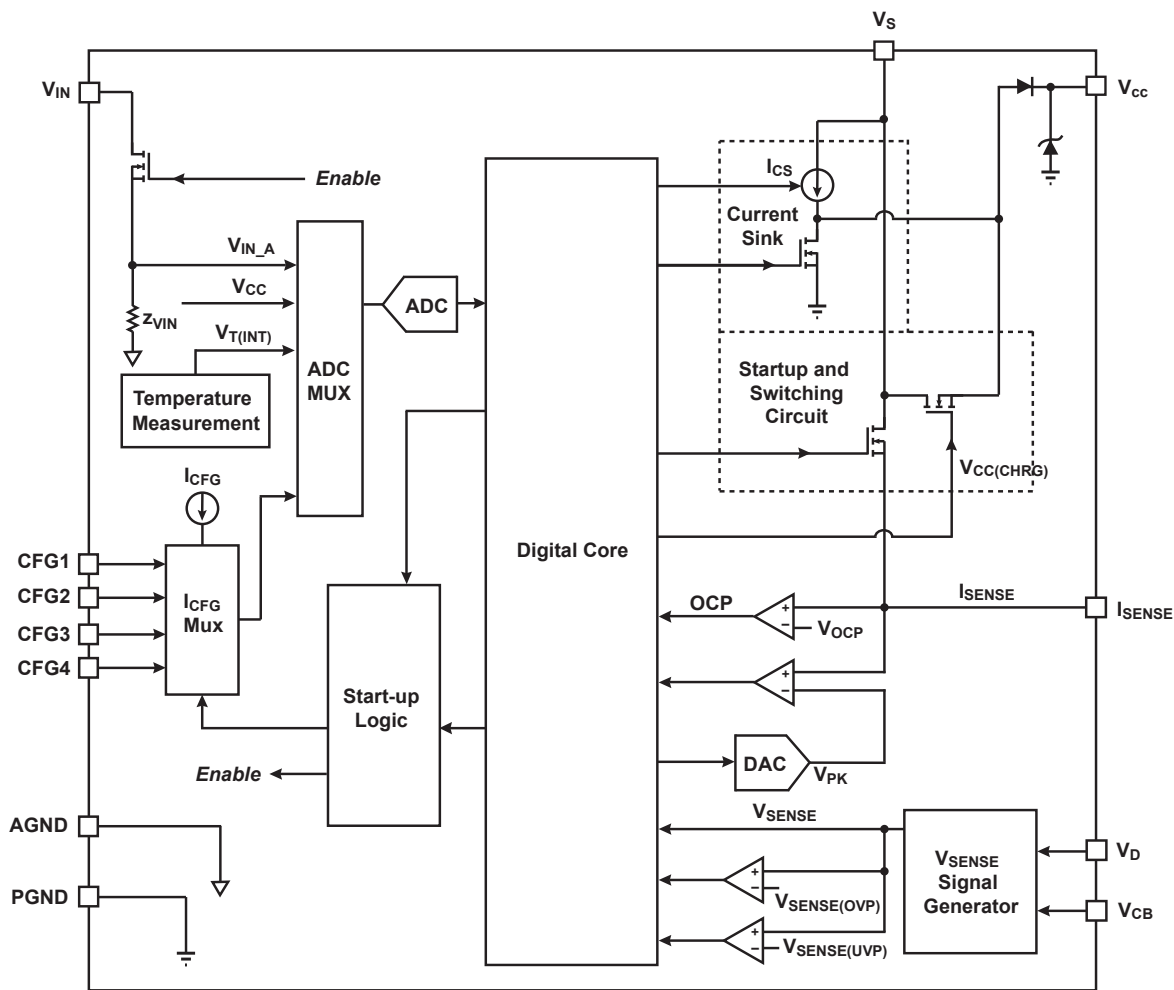

Figure 8.1 : iW3688 Functional Block Diagram

AC/DC Advanced Digital Power Controller for Single-Stage Dimmable LED Drivers

9.0 Theory of Operation

9.1 System Startup

This section provides information about iW3688 system start up, which includes the IC startup, wall dimmer detection, and the LED current soft start.

9.1.1 IC Startup

When AC voltage is applied, the gate voltage of MOSFET, V_G is charged up through RC circuit (R6, and C5 in Figure 11.1). When $V_{GS} > V_{GS(TH)}$, the MOSFET starts to turn on and charge the V_{CC} capacitors (C7 and C8 in Figure 11.1). When V_{CC} voltage reaches V_{CC} start-up threshold $V_{CC(ST)}$, the iW3688's control logic is activated and the IC starts up.

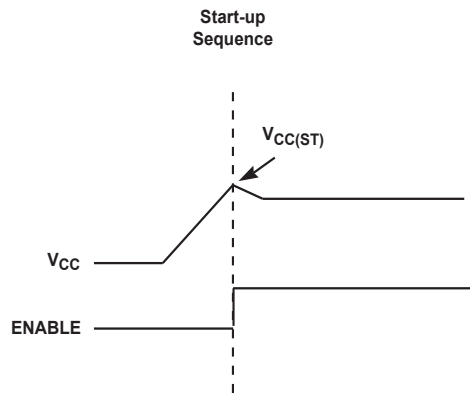

Figure 9.1 : Start-up Sequence Diagram

9.1.2 Wall Dimmer Detection

There are two basic categories of phase-cut wall dimmers: leading-edge dimmers and trailing-edge dimmers. If the AC voltage rises at the phase-cut edge, the dimmer is called leading-edge dimmer (shown in Figure 9.2). Otherwise it is called trailing-edge dimmer (shown in Figure 9.3). Normally, a leading-edge dimmer is either an R-type or RL-type; a trailing-edge dimmer is an RC-type.

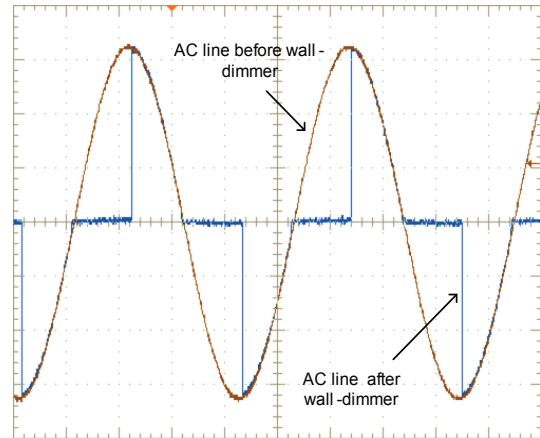

Figure 9.2 : Leading-Edge Wall Dimmer Waveforms

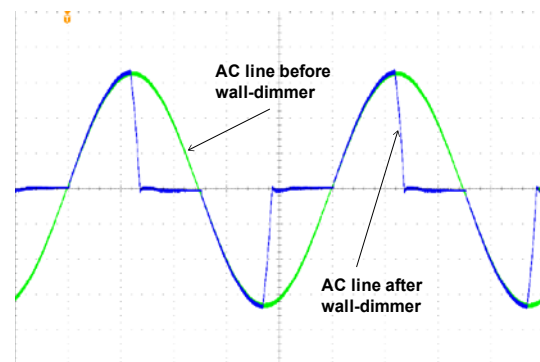

Figure 9.3 : Trailing-Edge Wall Dimmer Waveforms

The dimmer detection stage occurs in the iW3688 immediately after IC starts up. During this stage, the iW3688 stays in current sink mode to place a low impedance load on the AC line, where the current through MOSFET is regulated by the Digital Core. As a result, the dimmer type (no-dimmer, leading-edge, or trailing-edge) can be accurately detected.

The dimmer type is determined by sensing the slope of the input AC voltage and the dimming phase angle. A fast rising edge of the input AC voltage indicates a leading-edge dimmer. A large dimming phase angle indicates no dimmer is on the line. Otherwise, a trailing-edge dimmer is detected.

When the V_{IN_A} signal is above $V_{IN(ST)}$ for 500 μ s and the AC line frequency is within the range, the AC input signal is qualified for startup. If V_{CC} drops below $V_{CC(UVL)}$, the iW3688 resets and the startup sequence is initiated.

9.1.3 LED Current Soft-Start

After the iW3688 qualifies the AC input signal, the buck-boost or flyback converter immediately starts to deliver

AC/DC Advanced Digital Power Controller for Single-Stage Dimmable LED Drivers

current to the LED load. A soft-start algorithm is applied to the buck-boost or flyback converter to gradually ramp up the LED current.

If a dimmer is connected, the driver starts immediately into leading-edge or trailing-edge mode operation (refer to section 9.3.1 and 9.3.2 for details) to interface with the dimmer. If no dimmer is connected, the driver starts no-dimmer mode operation (refer to section 9.3.3 for details).

9.2 Dimming Curve

When a leading-edge or a trailing-edge dimmer is detected, the iW3688 adjusts the output current to a certain ratio of the nominal output current, based on the dimming phase angle detected. This ratio between the desired output current to the nominal output current is called the dimming percentage. A typical mapping between the dimming phase angle and the dimming percentage is shown in Figure 10.6. All the dimming curves of the iW3688 fall within the limits of the NEMA SSL6 and SSL7 standard (shown in Figure 10.6). The iW3688 updates the dimming percentage every half-AC-cycle based on the detected dimming phase angle to ensure fast dimming response.

9.3 Current Sink and Switching Circuit Control

This section provides information about how the iW3688 controls the current sink circuit and the switching circuit during leading-edge dimmer mode, trailing-edge dimmer mode, and no-dimmer mode.

9.3.1 Leading-Edge Dimmer Mode

If a leading-edge dimmer is detected, the iW3688 enters into leading-edge dimmer mode. The current sink circuit and switching circuit inside iW3688 turn on alternatively.

The current sink circuit and switching circuit control during leading-edge dimmer mode can be split into six operating sections, as shown in Figure 9.4.

During section 1, the TRIAC in the leading-edge dimmer is turned off and the dimmer requires a low impedance load to charge its internal timing circuit. The regulated current of the current sink circuit is set to a high limit while the switching circuit is disabled. When V_{IN_A} exceeds 0.228V for more than 40 μ s, the iW3688 enters into section 2. In section 2, the regulated current of section 1 is gradually transitioned to match the average switching current of section 3. When the transition is over, the iW3688 enters section 3, where the current sink circuit is disabled and the switching circuit begins its operation. The duration of section 3 is determined by the desired output current to be delivered to the LEDs. Once the energy required to obtain the desired output current

is delivered to the LEDs, the iW3688 disables the switching circuit and enters section 4. In section 4, the current sink circuit is enabled, which provides a gradual transition of MOSFET source current. During this transition, the averaged MOSFET source current is decreased to zero from the averaged switching current in section 3. When the MOSFET source current reaches zero, the iW3688 enters section 5, which is called the blanking period. During this period, no switching or current sink is present to minimize power loss and ensure the TRIAC in the dimmer is turned off. When V_{IN_A} falls below 0.184V, the iW3688 enters section 6. In section 6, the current sink circuit is enabled and the sinking current is transitioned from zero to the regulated current level in section 1. At the time when the sinking current reaches the regulated current in section 1, the iW3688 enters section 1. This provides a low impedance load to quickly discharge the capacitance of the driver board. The sinking current naturally goes to zero when the input and RC snubber capacitors (C1, C2, and C3 in Figure 11.1) have been fully discharged.

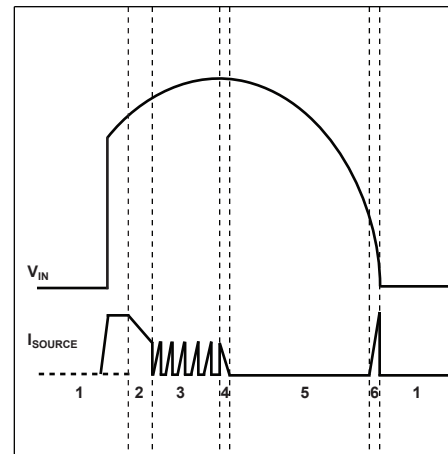

Figure 9.4 : Leading Edge Dimmer Mode Operation

9.3.2 Trailing-Edge Dimmer Mode

If a trailing-edge dimmer is detected, the iW3688 enters into trailing-edge dimmer mode. The current sink circuit and switching circuit inside iW3688 turn on alternatively.

The current sink circuit and switching circuit control during trailing-edge dimmer mode can be split into four operating sections, as shown in Figure 9.5.

During section 1, the trailing-edge dimmer requires a low impedance load to charge its internal supply voltage and detect the next zero-crossing. The regulated current of the current sink circuit is set to a high limit while the switching circuit is disabled. When V_{IN_A} exceeds 0.228V, the iW3688 enters into section 2. During section 2, the sinking current is gradually reduced from the regulated current of section 1 to zero. When the sinking current reaches zero, the iW3688

AC/DC Advanced Digital Power Controller for Single-Stage Dimmable LED Drivers

enters section 3. During section 3, both the current sink circuit and the switching circuit are disabled. In section 4, the iW3688 begins to deliver energy to output of the LED driver until the trailing-edge dimmer turns off. After section 4, the iW3688 disables the switching circuit and enters section 1. This provides a low impedance load to quickly discharge the capacitors of the dimmer and driver board.

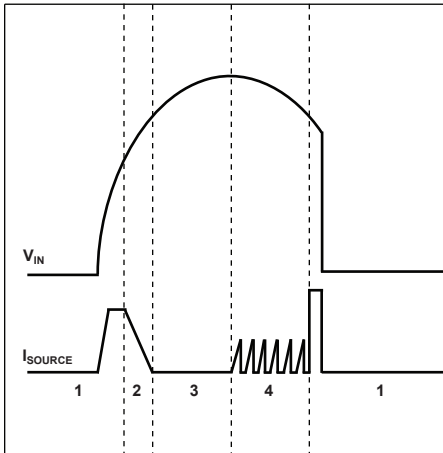

Figure 9.5 : Trailing Edge Dimmer Mode Operation

9.3.3 No-dimmer Mode

If there is no dimmer on the line, the iW3688 operates in no-dimmer mode to optimize power factor and to minimize harmonic distortion. The current sink circuit is disabled in this mode and only the switching circuit is used.

9.3.4 Controller Power Management

Unlike most off-line LED controllers, the iW3688 does not rely on auxiliary winding of the main power inductor/transformer to supply the operating current. Instead, it uses Dialog’s proprietary multi-path charging technology to sustain the V_{CC} voltage. Also, a lower nominal V_{CC} level is made possible with source switching structure, which reduces the IC power consumption and enables the use of a smaller size V_{CC} capacitor.

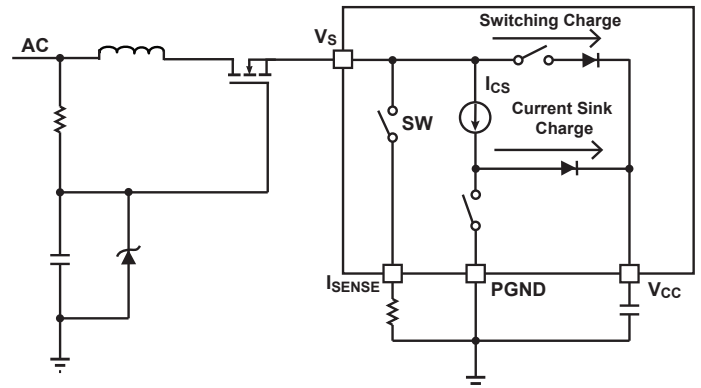

Figure 9.6 : V_{CC} Charging Circuit

The iW3688’s operating current is supplied by two paths (shown in Figure 9.6). The first path, called switching charge, re-directs the switching current into the V_{CC} capacitor when MOSFET is turned on. The second path, called sinking charge, re-directs the sinking current into V_{CC} capacitor. When there is no dimmer on the line, only the switching charge is used to achieve high efficiency. When there is a dimmer on the line, both switching and sinking charge are used to ensure V_{CC} is sustained across the entire dimming range.

The iW3688 regulates the V_{CC} voltage by adjusting the duration of the charging time. V_{CC} voltage is smoothly regulated to the nominal level when the iW3688 operates in no-dimmer mode. When the iW3688 operates in dimmer mode, the window for V_{CC} charging is limited. Therefore, the iW3688 charges the V_{CC} voltage to $V_{CC(HIGH)}$ in the charging window. Although V_{CC} voltage droops before next charging window, the iW3688 guarantees V_{CC} level is always above $V_{CC(UVL)}$ when a proper sized V_{CC} capacitor is used.

9.4 Output Current Regulation

This section provides information about iW3688 output current regulation, which incorporates the Dialog-patented PrimAccurate™ technology.

AC/DC Advanced Digital Power Controller for Single-Stage Dimmable LED Drivers

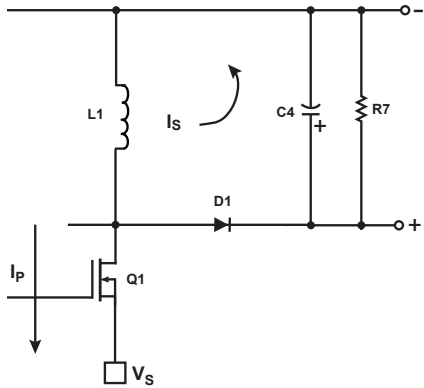

Figure 9.7 : Inductor Current Flow in Switching Mode

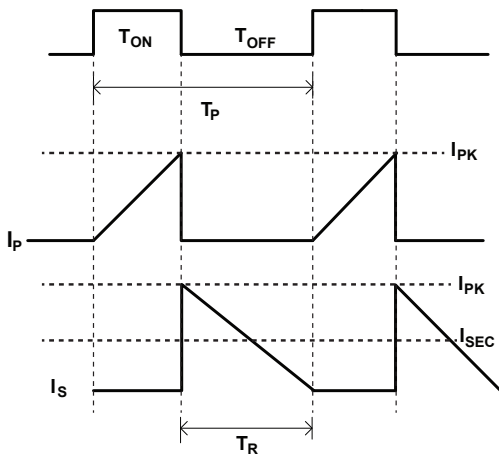

Figure 9.8 : Cycle-to-Cycle Peak Current Regulation

In iW3688, output current regulation is implemented through peak current control in switching mode. Figure 9.7 and 9.8 show the basic principle of this peak current regulation during the switching mode. During T_{ON} , the main switch Q1 (shown in Figure 9.7) is turned on and the current, I_P , flows through the primary side of the buck-boost converter and Q1. I_P ramps up linearly and causes energy to build up in the power inductor L1 (shown in Figure 9.7). The iW3688 continuously monitors I_{SENSE} pin voltage, when it reaches V_{PK} (shown in Figure 8.1), it turns off the switching circuit. At this time, I_P reaches peak current regulation level I_{PK} (shown in Figure 9.7 and 9.8). After Q1 is turned off, the current in L1 ramps down linearly through D1 (shown in Figure 9.7), until the energy stored in the power inductor is discharged. During this period, the current through L1 flows to the secondary side of the buck-boost/flyback converter, which is called I_S .

9.4.1 Output Current Regulation in No-dimmer Mode

In no-dimmer mode, V_{PK} is designed to be proportional to the input voltage shape with a lower limit (shown in Figure 9.9). The buck-boost or flyback converter operates in critical discontinuous conduction mode (CDCM) if the switching frequency of main MOSFET does not exceed the $f_{SW(MAX)}$. Otherwise, if the switching frequency reaches the $f_{SW(MAX)}$, the power converter operates in discontinuous conduction mode (DCM).

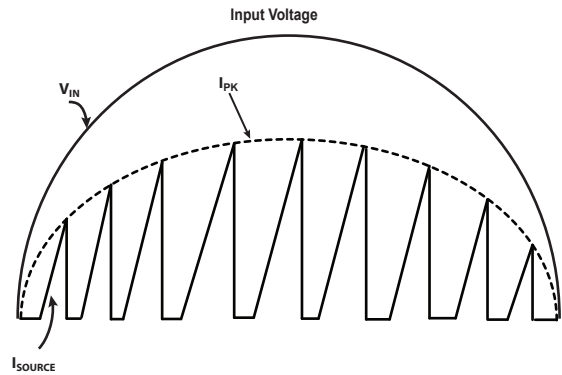

Figure 9.9 : Peak Current Regulation in No-dimmer Mode

As shown in Figure 9.8, the average current of I_S in one switching cycle can be expressed by I_{SEC} , where

$$I_{SEC} = 0.5 \times I_{PK} \times \frac{T_R}{T_P} \tag{9.1}$$

where I_{PK} is the peak value of the L1 current, T_R is the L1 current ramp-down time, and T_P is the entire switching period.

The I_{PK} is determined by the voltage generated on the current sense resistor R19 (shown in Figure 11.1): $I_{PK} = V_{PK} / R19$. Therefore, the equation can be written as

$$I_{SEC} = 0.5 \times \frac{V_{PK}}{R19} \times \frac{T_R}{T_P} \tag{9.2}$$

In steady state, the average output current is equal to the average I_{SEC} over one half-AC-cycle. Therefore, the average output current can be obtained by averaging equation 9.2 over one half-AC-cycle.

The iW3688 regulates the averaged $V_{PK} * (Tr/Tp)$ to be a constant over one AC half cycle. Therefore, the nominal output current $I_{OUT(NOM)}$ can be determined by equation 9.3.

AC/DC Advanced Digital Power Controller for Single-Stage Dimmable LED Drivers

$$I_{OUT(NOM)} = \frac{0.5}{R19} \times 0.35V \times \eta \quad (9.3)$$

η is the converter efficiency.

9.4.2 Output Current Regulation in Dimmer Mode

In dimmer mode, V_{PK} is a fixed value determined by resistor configuration. The switching frequency (f_{SW}) is also a fixed value based on resistor configuration (see Section 9.5 for details). If the buck-boost or flyback is operating in DCM, a fixed V_{PK} and f_{SW} control can achieve stable I_{SEC} regulation because the energy delivered to the LED is fixed regardless of input voltage variation. If the buck-boost or flyback is operating in CCM, this stable I_{SEC} regulation cannot be guaranteed. Therefore, the preset V_{PK} and f_{SW} values need to ensure the buck-boost or flyback is operating in DCM. When V_{IN} is low, the iW3688 drops the V_{PK} level to ensure DCM operation (see Figure 9.10).

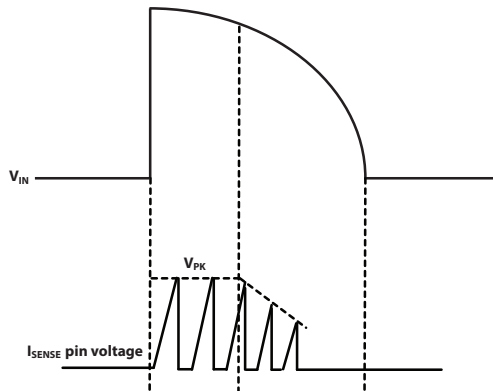

Figure 9.10 : Peak Current Regulation in Dimmer Mode

During dimmer mode operation, the output current is regulated with a closed loop control. The reference output current, $I_{OUT(DIM)}$, is calculated by equation 9.4. The instantaneous I_{SEC} current delivered to the output side is accumulated every switching cycle when switching is enabled.

$$I_{OUT(DIM)} = I_{OUT(NOM)} \times \text{dimming percentage} \quad (9.4)$$

When the accumulated instantaneous I_{SEC} current in one half-AC-cycle reaches $I_{OUT(DIM)}$, the iW3688 disables the switching circuit.

9.5 Configuration Function

At start-up, a current source in the iW3688 drives the configuration current I_{CFG} (100 μ A) into CFG1–CFG4 pin alternatively (shown in Figure 8.1). The iW3688 reads their pin voltages respectively to determine the configuration options.

CFG1 pin configuration selects the temperature de-rating start point. CFG2 optimizes the control algorithm for power and NV_O^* , and CFG2 selects the output current percentage at 70% dimming phase. CFG3 pin configuration selects V_{PK} high limit value at dimmer mode. CFG4 pin configuration selects switching frequency at dimmer mode.

By choosing different resistor values for R17, R18, R21, and R22 (shown in Figure 11.1), different configuration values are selected (illustrated in Table 9.1 - 9.4).

CFG1 Option Pin3 CFG	CFG1 Pin Resistor (R18 in Fig. 11.1)			Temperature Derating Starting Point (°C) (Internal Sensor) (Fig. 9-11)
	Typical Value (k Ω)	Min Value (k Ω)	Max Value (k Ω)	
0	0.40		0.69	disable temperature derating
1	1.65	1.39	1.91	100
2	3.00	2.78	3.22	105
3	4.45	4.28	4.62	110
4	6.05	5.88	6.22	115
5	7.85	7.70	8.00	120
6	9.88	9.74	10.01	125
7	12.18	12.04	12.31	130
8	14.85	14.67	15.03	135

Table 9.1 CFG1 Pin Configuration Resistor Values

CFG2 Option Pin2 VPP	CFG2 Pin Resistor (R17 in Fig. 11.1)			Power Level/ NV_O^* I_{OUT} at 70% Dimming Phase
	Typical Value (k Ω)	Min Value (k Ω)	Max Value (k Ω)	
0	0.40		0.69	> 6W/60V-120V/92%
1	1.65	1.39	1.91	> 6W/60V-120V/87%
2	3.00	2.78	3.22	> 6W/30V-60V/92%
3	4.45	4.28	4.62	> 6W/30V-60V/87%
4	6.05	5.88	6.22	< 6W/60V-120V/92%
5	7.85	7.70	8.00	< 6W/60V-120V/87%
6	9.88	9.74	10.01	< 6W/30V-60V/92%
7	12.18	12.04	12.31	< 6W/30V-60V/87%

*: NV_O is the product of the turns ratio and output voltage.

Table 9.2 CFG2 Pin Configuration Resistor Values

AC/DC Advanced Digital Power Controller for Single-Stage Dimmable LED Drivers

CFG3 Option Pin10 SDA	CFG3 Pin Resistor (R21 in Fig. 11.1) (±10%)			V _{PK} at Dimmer Mode (V)
	Typical Value (kΩ)	Min Value (kΩ)	Max Value (kΩ)	
0	0.40		0.69	0.75
1	1.65	1.39	1.91	0.8
2	3.00	2.78	3.22	0.85
3	4.45	4.28	4.62	0.9
4	6.05	5.88	6.22	0.95
5	7.85	7.70	8.00	1
6	9.88	9.74	10.01	1.05
7	12.18	12.04	12.31	1.1
8	14.85	14.67	15.03	1.15

Table 9.3 CFG3 Pin Configuration Resistor Values

CFG4 Option Pin11 SCL	CFG4 Pin Resistor (R22 in Fig. 11.1)			Switching Frequency at Dimmer Mode (kHz)
	Typical Value (kΩ)	Min Value (kΩ)	Max Value (kΩ)	
0	0.40		0.69	40
1	1.65	1.39	1.91	45
2	3.00	2.78	3.22	50
3	4.45	4.28	4.62	55
4	6.05	5.88	6.22	60
5	7.85	7.70	8.00	65
6	9.88	9.74	10.01	70
7	12.18	12.04	12.31	75
8	14.85	14.67	15.03	80

Table 9.4 CFG4 Pin Configuration Resistor Values

9.6 V_{SENSE} Direct Sensing

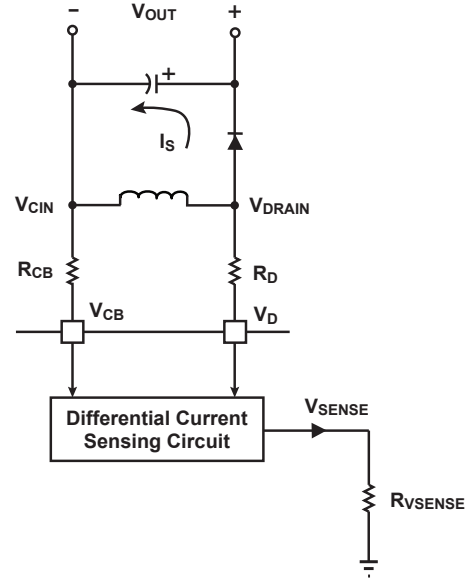

Figure 9.11 : V_{SENSE} Circuit Inside iW3688

In conventional LED driver solutions, there is an auxiliary winding in the main inductor/transformer. Three main functions of this auxiliary winding are: 1. To supply V_{CC} for controller IC; 2. To provide output voltage information; 3. To provide magnetic flux information of the inductor. As mentioned in 9.3.4, the iW3688 does not rely on auxiliary winding to charge V_{CC}. In addition, Dialog’s proprietary V_{SENSE} Direct Sensing technology allows the iW3688 to obtain LED output voltage and magnetic flux information without an auxiliary winding.

Inside the iW3688, there is a high performance differential current sensing circuit between V_D and V_{CB} pin (shown in Figure 9.11). This circuit generates a differential current that is equal to the current flow into V_D pin subtracted by the current flow into V_{CB} pin. This differential current is directed to an internal precise resistor, R_{VSENSE}, to generate a voltage called V_{SENSE}. V_{SENSE} is essentially a scaled-down version of V_{DRAIN} minus V_{CIN}, which is the same as the auxiliary winding generated signal.

The resistances of R_{CB} and R_D are determined by the nominal output voltage, V_{OUT}. In Figure 11.1 R_{CB} refers to R13, and R_D refers to R15.

$$V_{SENSE} = \left(\frac{V_{DRAIN}}{R_D} - \frac{V_{CIN}}{R_{CB}} \right) \times R_{VSENSE} \tag{9.5}$$

AC/DC Advanced Digital Power Controller for Single-Stage Dimmable LED Drivers

During the period of T_R (shown in Figure 9.8), V_{DRAIN} minus V_{CIN} is approximately equal to V_{OUT} . By making R_{CB} and R_D the same, their values can be determined by

$$R_{CB} = R_D = \frac{V_{OUT}}{V_{SENSE}} \times R_{VSENSE} \quad (9.6)$$

9.7 Protection Features

This section provides information about iW3688 protection features.

9.7.1 Output Over-Voltage/LED Open Protection

The iW3688 includes a function that protects against an output over-voltage.

The output voltage is monitored by the V_{SENSE} voltage (refer to Section 9.6). If the V_{SENSE} voltage exceeds $V_{SENSE(OVP)}$, the iW3688 shuts down the switching circuit and current sink circuit (shown in Figure 8.1) immediately. As a result, MOSFET is turned off. After the shutdown of current sink and switching circuits, the iW3688 remains powered, while V_{CC} continues to discharge. In order to avoid over-charging of the output voltage, the iW3688 employs an extended discharge time as described below if V_{CC} does not drop below $V_{CC(UVL)}$. Otherwise, when V_{CC} drops below $V_{CC(UVL)}$, the iW3688 resets itself and then initiates a new soft-start cycle.

Under the fault condition, the iW3688 tries to start up for three consecutive times. If all three start-up attempts fail, the iW3688 enters an inactive mode, during which the iW3688 does not respond to the V_{CC} power-on requests. The iW3688 is activated again after it sees 29 start-up attempts. Typically, this extended discharge time is around three to five seconds.

9.7.2 Output Short Protection

The iW3688 includes a function that protects against an output short-circuit fault.

When output is shorted, V_{SENSE} is below $V_{SENSE(UVP)}$. As a result, an output short fault is detected. The iW3688 shuts down the switching circuit and current sink circuit (shown in Figure 8.1) immediately. As a result, MOSFET is turned off. After the turn-off of MOSFET, the iW3688 remains powered while V_{CC} continues to discharge. In order to avoid excessive power stress due to auto-restart, the iW3688 employs an extended discharge time as described in section 9.7.1 if V_{CC} does not drop below $V_{CC(UVL)}$. Otherwise, when V_{CC} drops below $V_{CC(UVL)}$, the iW3688 resets itself and then initiates a new soft-start cycle.

To support applications with high output capacitance, output short protection is not activated during the initial LED current soft start period. This allows the voltage to build up in the output capacitor without triggering the protection.

9.7.3 Temperature De-Rating and Over-Temperature Protection

The iW3688 can detect and protect against over-temperature event. The iW3688 utilizes an internal sensor for temperature measurement.

When the monitored temperature reaches $T_{DERATE(ST)}$, the maximum output current limit begins to reduce linearly from 100% to 70% of the nominal value until the temperature reaches $T_{DERATE(FINISH)}$ threshold as shown in Figure 9.12, where $T_{DERATE(FINISH)} = T_{DERATE(ST)} + 20^\circ\text{C}$. At $T_{DERATE(FINISH)}$, the maximum output current limit is clamped to 70%. If the temperature further increases to $T_{OTP(START)}$, the iW3688 shuts down.

The iW3688 remains in shutdown mode as long as the monitored temperature is above $T_{OTP(START)}$. If the detected temperature falls below $T_{OTP(START)}$ at anytime, the iW3688 starts up. From $T_{DERATE(FINISH)}$ to $T_{DERATE(ST)}$, the maximum output current limit increases linearly from 70% to 100% as shown in Figure 9.12. The device goes back to normal operation if the sensed temperature falls below $T_{DERATE(ST)}$. This bi-directional operation enables the LED current thermal fold-back instead of an abrupt shut-down of the LED current.

The values of $T_{DERATE(ST)}$ and $T_{DERATE(FINISH)}$ can be adjusted through the CFG1 pin resistor (refer to Section 9.5).

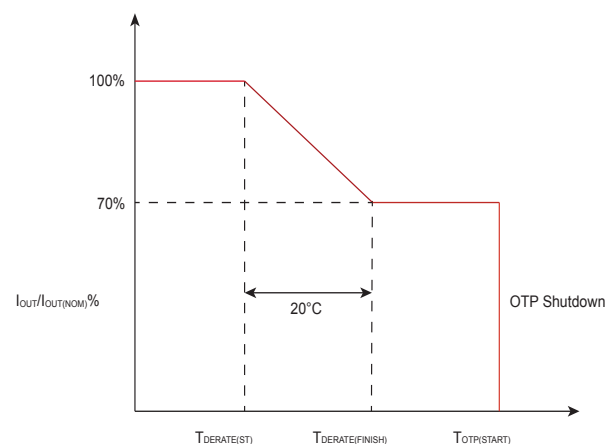

Figure 9.12 : Temperature DeRating and OTP

9.7.4 Over-Current Protection

Over-current protection (OCP) is a feature that is built into the iW3688.

AC/DC Advanced Digital Power Controller for Single-Stage Dimmable LED Drivers

With the I_{SENSE} pin, the iW3688 is able to monitor the primary peak current of the buck-boost or flyback converter during switching mode. This allows for cycle-by-cycle peak current control and limit. When the primary peak current multiplied by the I_{SENSE} pin sensing resistor (R19 in Figure 11.1) is greater than V_{OCP} , over-current is detected and the iW3688 immediately shuts down the switching circuit until the next switching cycle. The switching circuit sends out switching pulse in the next switching cycle, and the switching pulse continues if V_{OCP} is not reached; or, if V_{OCP} is reached, the switching pulse turns off again.

9.7.5 Current Sensing Resistor Short Protection

The iW3688 uses a MOSFET as its main switch for the buck-boost or flyback converter. If the I_{SENSE} pin sensing resistor (R19 in Figure 11.1) is shorted, there is a potential danger of the over-current condition not being detected. Thus the iW3688 is designed to detect this sensing-resistor short fault. When the sensing resistor short fault is detected, the iW3688 shuts down the switching circuit and current sink circuit (shown in Figure 8.1) immediately. As a result, MOSFET is turned off. After the turn-off of MOSFET, the iW3688 remains powered while V_{CC} continues to discharge. In order to prevent over-stress of power circuit components, the iW3688 employs an extended discharge time as described in section 9.7.1 if V_{CC} does not drop below $V_{CC(UVL)}$. Otherwise, when V_{CC} drops below $V_{CC(UVL)}$, the iW3688 resets itself and then initiates a new soft-start cycle.

9.7.6 Current Sense Resistor Open Protection

If the I_{SENSE} pin sensing resistor (R19 in Figure 11.1) is open and not being detected, it may cause potential damage to the internal circuit during the switching mode. Thus, the iW3688 is designed to detect I_{SENSE} pin open fault. When the I_{SENSE} pin open fault is detected, the iW3688 shuts down the switching circuit and current sink circuit (shown in Figure 8.1) immediately. As a result, MOSFET is turned off. After the turn-off of MOSFET, the iW3688 remains powered while V_{CC} continues to discharge. In order to prevent over-stress of power circuit components, the iW3688 employs an extended discharge time as described in section 9.7.1 if V_{CC} does not drop below $V_{CC(UVL)}$. Otherwise, when V_{CC} drops below $V_{CC(UVL)}$, the iW3688 resets itself and then initiates a new soft-start cycle.

9.7.7 AC Input Over-Voltage Protection

The iW3688 supports the over-voltage protection of AC input.

If the V_{IN_A} is higher than $V_{IN(OVP)}$ continuously for 2ms within every 16ms period, and this condition lasts for eight consecutive half AC cycles, the iW3688 shuts down the switching circuit and current sink circuit (shown in Figure 8.1) immediately. As a result, MOSFET is turned off. After the turn-off of MOSFET, the iW3688 remains powered while V_{CC} continues to discharge. The iW3688 employs an extended discharge time (as described in section 9.7.1) before restart if V_{CC} does not drop below $V_{CC(UVL)}$. Otherwise, when V_{CC} drops below $V_{CC(UVL)}$, the iW3688 resets itself and then initiates a new soft-start cycle.

AC/DC Advanced Digital Power Controller for Single-Stage Dimmable LED Drivers

10.0 Performance Characteristics

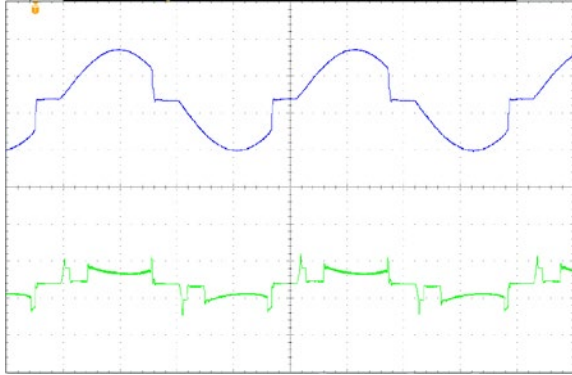

Figure 10.1 : Trailing-Edge Dimmer

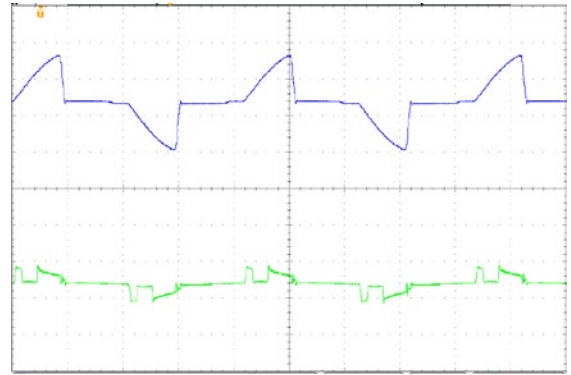

Figure 10.2 : Trailing-Edge Dimmer 2

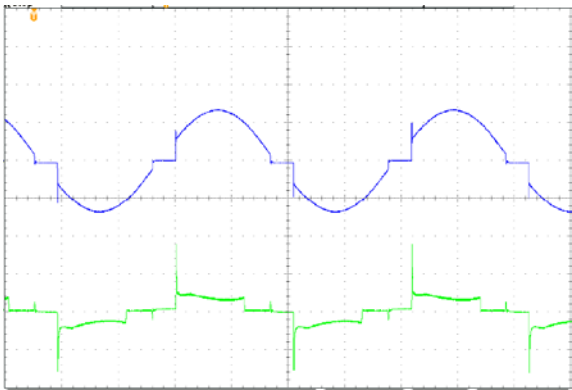

Figure 10.3 : Leading-Edge Dimmer

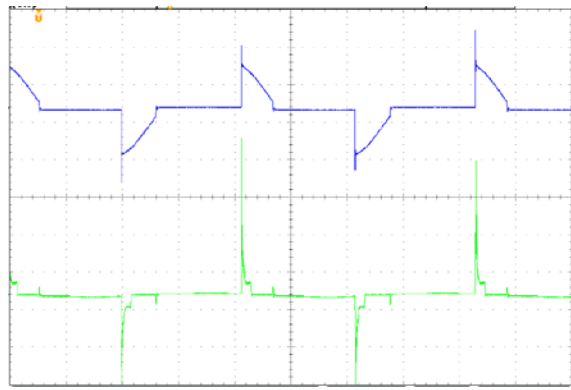

Figure 10.4 : Leading-Edge Dimmer 2

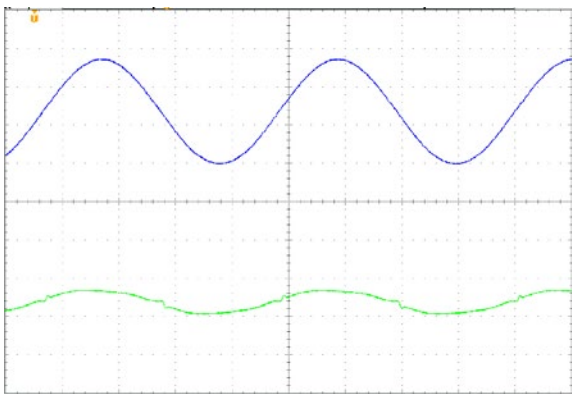

Figure 10.5 : No Dimmer

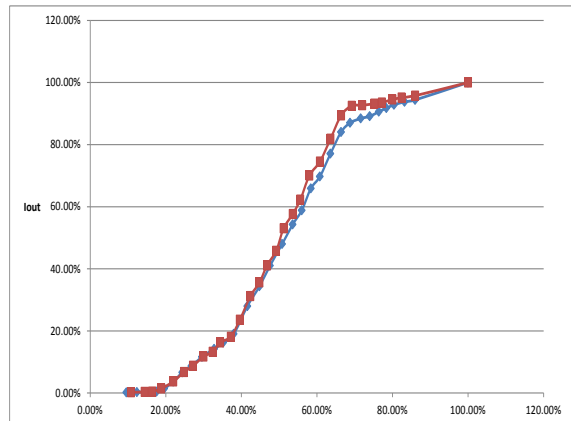

Figure 10.6 : Dimming Curve

AC/DC Advanced Digital Power Controller for Single-Stage Dimmable LED Drivers

11.0 Typical Application Schematic

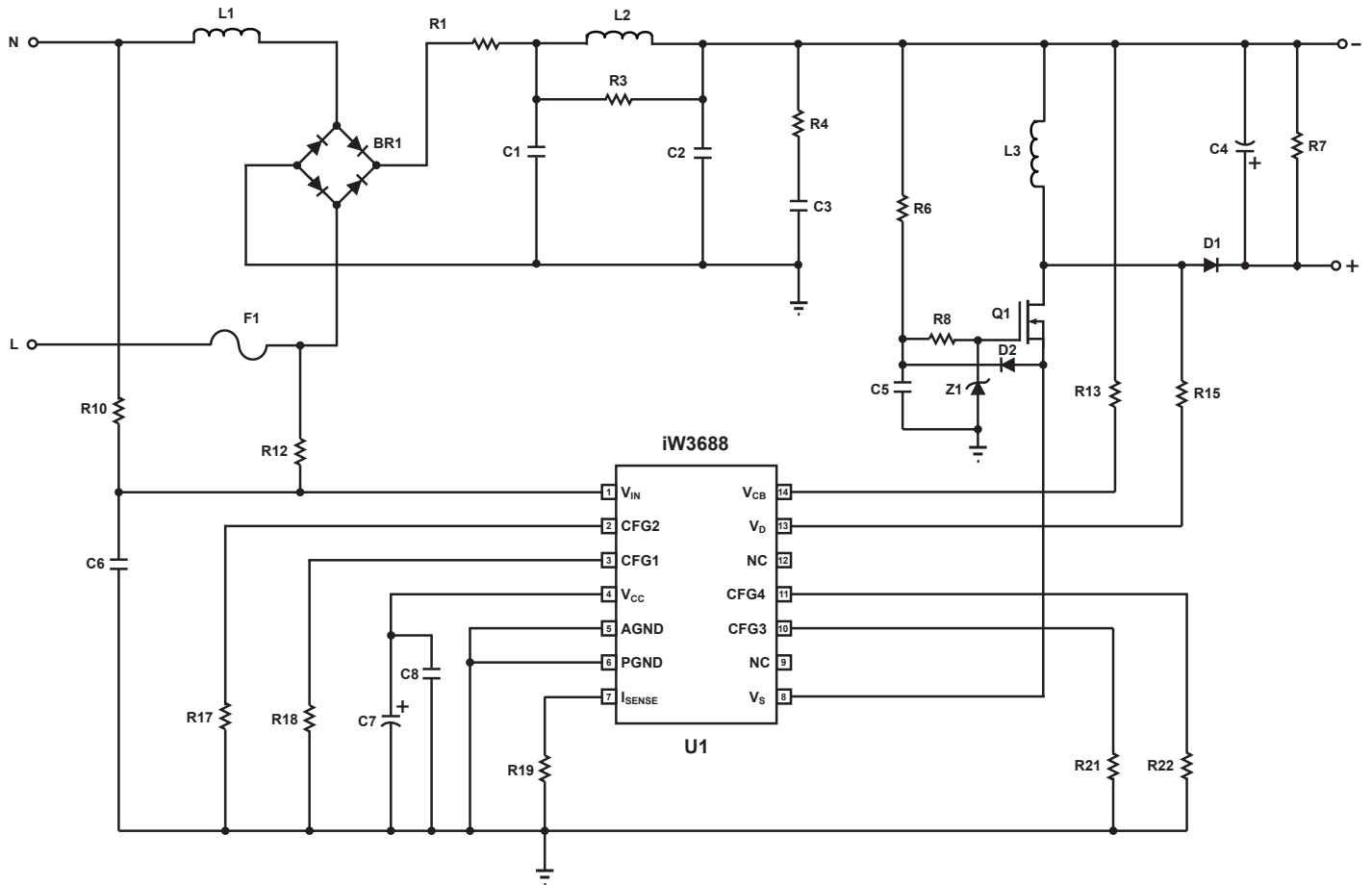

Figure 11.1 : Typical Application Circuit

12.0 Product Navigation

For 20W or higher power applications, visit the products below:

Part Number	Options
iW3600-00 or iW3605-02	120V _{AC} input
iW3600-01 or iW3605-02	230V _{AC} input

AC/DC Advanced Digital Power Controller for Single-Stage Dimmable LED Drivers

13.0 Physical Dimensions

14-Lead SOIC Package

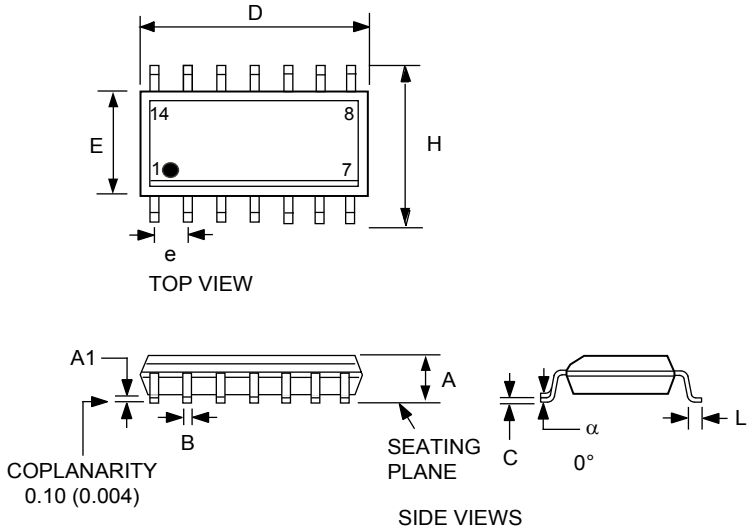

Symbol	Inches		Millimeters	
	MIN	MAX	MIN	MAX
A	0.053	0.069	1.35	1.75
A1	0.004	0.010	0.10	0.25
B	0.013	0.020	0.33	0.51
C	0.007	0.010	0.19	0.25
D	0.337	0.344	8.55	8.75
E	0.150	0.157	3.80	4.00
e	0.050 BSC		1.27 BSC	
H	0.228	0.244	5.80	6.20
N	0.086	0.094	2.18	2.39
M	0.118	0.126	3.00	3.20
L	0.016	0.050	0.40	1.27
α	0°	8°	0°	8°

Compliant to JEDEC Standard MS12F

Controlling dimensions are in inches; millimeter dimensions are for reference only

This product is RoHS compliant and Halide free.

Soldering Temperature Resistance:

[a] Package is IPC/JEDEC Std 020D Moisture Sensitivity Level 1

[b] Package exceeds JEDEC Std No. 22-A111 for Solder Immersion Resistance; package can withstand 10 s immersion < 260°C

Dimension D does not include mold flash, protrusions or gate burrs. Mold flash, protrusions or gate burrs shall not exceed 0.15 mm per end. Dimension E does not include interlead flash or protrusion. Interlead flash or protrusion shall not exceed 0.25 mm per side.

The package top may be smaller than the package bottom. Dimensions D and E are determined at the outermost extremes of the plastic body exclusive of mold flash, tie bar burrs, gate burrs and interlead flash, but including any mismatch between the top and bottom of the plastic body.

14.0 Ordering Information

Part Number	Options	Package	Description
iW3688-00	120V _{AC} Input for up to 14W	SOIC-14	Tape & Reel ¹
iW3688-01	230V _{AC} Input for up to 14W	SOIC-14	Tape & Reel ¹
iW3688-20	120V _{AC} Input for 15W – 20W	SOIC-14	Tape & Reel ¹
iW3688-21	230V _{AC} Input for 15W – 20W	SOIC-14	Tape & Reel ¹
iW3688-30 ²	Universal Input for up to 14W	SOIC-14	Tape & Reel ¹

Note 1: Tape & Reel packing quantity is 2,500/reel. Minimum ordering quantity is 2,500.

Note 2: Contact Dialog Marketing for availability.

AC/DC Digital Power Controller for Single-Stage High Power Factor Dimmable LED Drivers

Disclaimer

Information in this document is believed to be accurate and reliable. However, Dialog Semiconductor does not give any representations or warranties, expressed or implied, as to the accuracy or completeness of such information. Dialog Semiconductor furthermore takes no responsibility whatsoever for the content in this document if provided by any information source outside of Dialog Semiconductor.

Dialog Semiconductor reserves the right to change without notice the information published in this document, including without limitation the specification and the design of the related semiconductor products, software and applications.

Applications, software, and semiconductor products described in this document are for illustrative purposes only. Dialog Semiconductor makes no representation or warranty that such applications, software and semiconductor products will be suitable for the specified use without further testing or modification. Unless otherwise agreed in writing, such testing or modification is the sole responsibility of the customer and Dialog Semiconductor excludes all liability in this respect.

Customer notes that nothing in this document may be construed as a license for customer to use the Dialog Semiconductor products, software and applications referred to in this document. Such license must be separately sought by customer with Dialog Semiconductor.

All use of Dialog Semiconductor products, software and applications referred to in this document are subject to Dialog Semiconductor's [Standard Terms and Conditions of Sale](#), unless otherwise stated.

© Dialog Semiconductor GmbH. All rights reserved.

RoHS compliance

Dialog Semiconductor complies to European Directive 2001/95/EC and from 2 January 2013 onwards to European Directive 2011/65/EU concerning Restriction of Hazardous Substances (RoHS/RoHS2).

Dialog Semiconductor's statement on RoHS can be found on the customer portal <https://support.diasemi.com/>. RoHS certificates from our suppliers are available on request.

Contacting Dialog Semiconductor

United Kingdom

Dialog Semiconductor (UK) Ltd
Phone: +44 1793 757700

Germany

Dialog Semiconductor GmbH
Phone: +49 7021 805-0

The Netherlands

Dialog Semiconductor B.V.
Phone: +31 73 640 88 22

Email

info_pcbg@diasemi.com

North America

Dialog Semiconductor Inc.
Phone: +1 408 845 8500

Japan

Dialog Semiconductor K. K.
Phone: +81 3 5425 4567

Taiwan

Dialog Semiconductor Taiwan
Phone: +886 8178 6222

Web site:

www.dialog-semiconductor.com

Singapore

Dialog Semiconductor Singapore
Phone: +65 64849929

Hong Kong

Dialog Semiconductor Hong Kong
Phone: +852 2607 4271

Korea

Dialog Semiconductor Korea
Phone: +82 2 3469 8200

China

*Dialog Semiconductor
(Shenzhen)*
Phone: +86 755 2981 3669

*Dialog Semiconductor
(Shanghai)*
Phone: +86 21 5178 2561

